



SKUTT

OPERATING
MANUAL

KILNMASTER®
AUTOMATIC KILNS

KILNMASTER®
CONTROLLERS





About thermocouples.

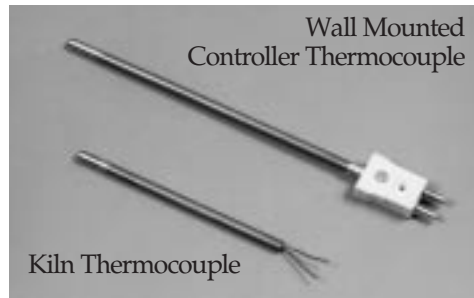

Skutt KilnMaster kilns are equipped with MI (mineral insulated) thermocouples, which feature long life, virtually no flaking, and ease of installation. Because of these improvements, an additional thermocouple is not included with your kiln. Thermocouple wear is progressive, so it may not be obvious.

Signs that a thermocouple may need replacing include:

1. A crack in the sheath of the thermocouple.
2. A *FAIL* message on the display.
3. Erratic temperature swings and/or a minus sign on the display.
4. A change in firing results as evidenced by overfiring or underfiring.

Thermocouple elements are available from your Skutt distributor or from Skutt Ceramic Products if a distributor is not conveniently located near you.

Table of Contents

Quick Start	1	Underglaze firing.....	16	Kiln Problems	31
The Cone Fire Mode.....	1	Ceramic glaze firing.....	16	Ware imperfections.....	32
The Ramp/Hold Mode.....	2	“Greenglaze” one-fire ceramics.....	16	Repairs	34
Introduction.....	3	Overglaze fires.....	16	Wall and slab brick repair	34
Features of the KilnMaster	4	Firing porcelain	17	Replacing elements.....	35
Skutt kiln/controller features	5	Firing stoneware	17	Replacing thermocouple.....	35
Wall Mounted KilnMaster.....	5	Firing glass.....	18	Glossary	35
Controller set up.....	6	Quick cone reference chart.....	18	Appendix 1 Specifications	37
Thermocouple	7	The KilnMaster Controller.....	18	Appendix 2 Cone Chart, Heat Work	37
Kiln settings	7	During the firing	18	Appendix 3 Display Messages.....	39
KilnMaster repairs	7	After each firing.....	18	Appendix 4 Error Messages.....	40
Automatic Kiln set up.....	8	Cone Fire Mode.....	19	Appendix 5 KM Wiring Diagrams	41
Locating your new kiln	8	Profiles.....	19	Appendix 6 KM-1 UL Listing.....	45
Unpacking and checking the kiln	8	Programming.....	21	Appendix 7 PK Production Kilns.....	45
Electrical requirements.....	10	Programming step by step	22	Production Kiln Wiring Diagrams.....	48
Preparation before firing.....	11	Ramp/Hold Mode	23	Index.....	50
First test firing	11	Programming.....	24	Ramp/Hold profile masters	52
General Ceramic Information.....	12	Programming step by step.....	24		
Precautions.....	13	Programming examples	26		
Loading: key to consistent results.....	13	Key Functions of the Controller	28		
Greenware for bisque firing.....	13	Temperature Scale Selection.....	28		
Glaze firing.....	14	Delay Start.....	28		
Porcelain and stoneware firings	14	Alarm.....	28		
Overglaze firings	14	Review.....	29		
Glass fusing & sagging firings	14	Cone Table	29		
General Firing Information	15	View	29		
Pre-firing checklist	15	Powering the Kiln.....	30		
Cold weather operation	15	Stop Firing.....	30		
Type of firing.....	16	Start Firing.....	30		
Venting.....	16	Questions and Troubleshooting	31		

KilnMaster® and EnviroVent® are registered trademarks of Skutt Ceramic Products, 6441 S.E. Johnson Creek Blvd., Portland, Oregon 97206-9594 Phone (503) 774-6000 FAX (503) 774-7833 © Copyright 1998. Skutt Ceramic Products. Printed in U.S.A.



Quick Start— All you need to start firing now!

If you:

- are an experienced electric kiln operator,
- know how to set up a new kiln and kiln wash shelves,
- know about doing the first test firing, and
- know how to load your ware—

you can use the following Quick Start Firing Instructions.

If this is your first new kiln, please take the time to read the set up and general ceramic information sections of this manual, for your safety and to ensure proper operation and long life of your quality Skutt kiln.

For those of you who have fired kilns before, this section offers a brief set of instructions for programming the controller in both Cone Fire and Ramp/Hold Modes. Be sure that your kiln is set up properly and your shelves are kiln washed.

Please refer to the section on The KilnMaster Controller for all the features, programming examples and detailed instructions on using the controller.

Activate the power source by **plugging in** the kiln or controller. “PF” will appear in the display window indicating that the power has been turned off for more than two minutes.

Press **Enter** to clear the message.

The touch pad should now be in IDLE mode and will now respond to key presses. The display will flash the internal temperature of the kiln, alternately with “IDLE.” The controller is ready to program when the temperature appears in the display window. All programming begins when the flashing internal kiln temperature is on the display.

To change from the default setting of °F to °C, press the **degrees F/C** key, then **Enter**. A decimal will appear in the lower right corner of the display window when in the centigrade mode.

You’ll notice different default displays. The Alarm default is **9999**. The Delay default is **00.00**. Numbers to left of the decimal are hours, to the right are minutes. Hold default is **00.00**, again in hours and minutes.

QUICK START: THE CONE FIRE MODE

The Cone Fire mode replicates your previous firing experience using cones in a kiln sitter. Use the **Hold** function to adjust your final results in the event the shelf cones are slightly underfired. Be careful not to add too much time (5-15 minutes is a good start). Please read Appendix 2 relating to Cones and Heat Work for more details.

1. From idle mode, press **Enter**, then **Cone Fire**.
2. Enter the **Cone number**. (Important: be sure to know the maturing temperature of your clay. For example, a Cone 05 is cooler than a Cone 5.) Press **Enter**.
3. Press one of the firing speeds, either **Slow, Medium, or Fast**. Press **Enter**.
4. Enter a hold time in hours and minutes or zero for no hold time. Press **Enter**.
5. The display will flash two times, and then show the internal kiln temperature indicating that the kiln is ready to fire.
6. Press **Start**.



QUICK START: THE RAMP/HOLD MODE

Important: To effectively use Ramp/ Hold mode, it is imperative to understand heat work theory. If you know the theory well, and if you have had experience with other programmable kilns or controllers, then the Quick Start instructions at right will be useful.

If not please read the complete Ramp/ Hold instructions beginning on page 23, and Appendix 2 for details.

The Ramp/ Hold mode can be used for all firing applications from glass to high fire porcelain and stoneware. This option allows you to create your own profiles with up to eight ramp and hold segments. Each segment has three components: heating rate, temperature and hold. If you are programming to approximate cone numbers, be sure to review the Appendix 2 for information on heat work.

Before you begin input, create a chart with all of the segments you plan to include in your program. You may have fewer than eight segments, but no more. Select either °F/ °C before you begin.

One can store up to six programs in permanent memory by assigning a **USER** number (program number) before inputting the required data. The next time that program is desired, simply select the appropriate **USER** number. When all **USER** numbers are programmed, it will be necessary to write over an existing number, which will erase it from memory.

1. From idle mode, press **Ramp/ Hold**.
2. Enter the **USER Number** of the program you wish to fire. If none has been entered, select **1**. Press **Enter**.
3. Enter the **number of segments** in your program. Press **Enter**.
4. Enter the first **heating rate** in degrees per hour. Press **Enter**.
5. Enter the **first temperature to reach**. Press **Enter**.
6. Enter the amount of **hold time** in hours and minutes, or zero for no hold time. Press **Enter**.
7. **Repeat** instructions 4-6 for each segment that will be programmed.
8. Enter the **ALAR** alarm temperature, or leave at the default setting of 9999 by pressing **Enter**.
9. The display will return to idle mode.
10. Press **Start**.

Segment	Rate	Temperature	Hold
1			
2			
3			
4			
5			
6			
7			
8			



The Skutt family of automatic kilns.

INTRODUCTION

Congratulations! You've made a great choice from the proven Skutt kiln line. First, read this entire manual before you do anything else. At Skutt Ceramic Products, we created and refined the multi-sided electric kiln. And although there are many imitators, frankly we still believe that no kiln is designed with more understanding or manufactured with more care. Even so, for complete safety and consistent results, you must understand the principles behind ceramic firing and how your kiln works.

Whether you have owned an electric kiln before or not, please take the time to read this manual from cover to cover. We think even the most experienced veteran will learn a few new tips.

This manual covers Skutt Automatic Kilns with built-in KilnMaster Controllers and wall-mounted KilnMaster Controllers for conventional kilns. Because both units have the same electronic functions, when we say "KilnMaster" or "controller" we are referring to the touch pad on either the kiln or the wall-mounted version.

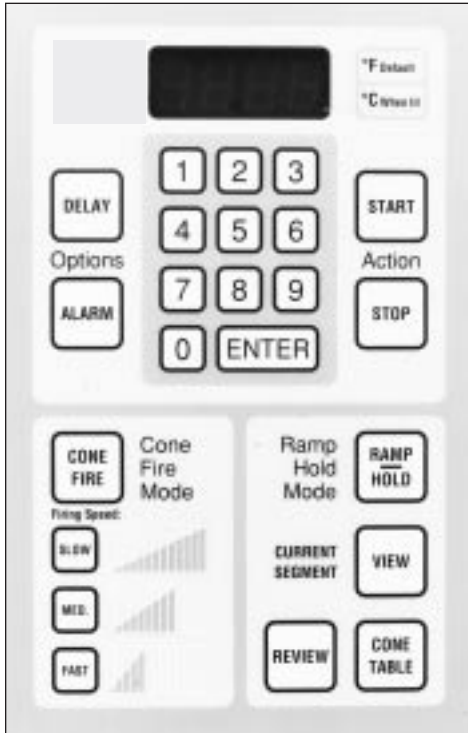

Features and benefits of the Skutt KilnMaster controller.

Easy to use. The display guides you through operating steps by a series of messages that ask for information. The internal temperature is displayed during the entire firing and during the cooling. Program by cone number. Simply select a cone number from the table and enter the speed you want for firing. The lower left half of the touchpad controls the Cone Fire functions; the right side controls Ramp/Hold functions. Review is appropriate for either mode.

Firing speed options. When firing from the Cone Fire mode, you can select from three preprogrammed ramp speeds: fast, medium or slow.

Multiple Ramp/Hold segments. When firing in the Ramp/Hold mode you can program up to eight different segments that include rate, temperature and hold time.

Permanent program memory. Permanent memory allows the controller to maintain values in the memory in case of power

failure. This feature also permits you to store up to six Ramp/Hold programs in memory, and to use them later by entering their program number.

Delay firing start. You can delay the start of a firing for up to 99 hours and 99 minutes.

Controlled cooling rate. Now you can program your own rate of cooling to achieve your specific results.

Program Review Option. The program you have entered can be reviewed before and during a firing. Pressing the View button displays the segment that is currently being executed during Ramp/Hold mode firings.

Cone table. This function shows you the equivalent temperature in degrees Fahrenheit or Centigrade that corresponds to a cone number, which is handy when programming Ramp/Hold firings.

Fahrenheit or Centigrade operation. Select either temperature scale at the touch of a button. Permanent memory allows the temperature scale and values to be continuously displayed until reprogrammed.

Programmable High Temperature Alarm. The program lets you set an alarm that will alert you when a specified tem-

perature has been reached. This allows you to check firing progress and to be present as shut-off or ramp-down occurs.

Safety Features. Power failure detection. Firing will continue after power interruptions which cause less than a 250° F drop in internal temperature. Firing will also continue in Cone Fire mode if the interruption causes less than a 100° F drop during the final 100° of a firing.

Thermocouple failure detection. The controller can detect a failed thermocouple and will turn the kiln off automatically.

Controller-operation failure detection. If a fault is detected in the controller the kiln will turn off automatically.

Designed and Manufactured in the United States. Licensed under Orton's Patent #4461616. In Cone Fire mode, the controller uses Orton's patented method to adjust final temperature to emulate cone "heat work". This is fully described in Appendix 2, Cone Chart and Heat Work.

UL and CSA Listed. The KilnMaster Controller is UL and CSA listed when factory installed in Skutt automatic kilns and when the wall-mounted KM-1 KilnMaster Controller is used with the UL-listed Skutt kiln models listed in Appendix 6.



What you'll find in a quality Skutt kiln—and why.

KilnMaster Controller. At the heart of your new kiln, or wall mounted KM-1, is the KilnMaster controller. This unit allows you much greater control over your kiln than ever before. It is essentially two controllers in one. You can fire by cone numbers or specify your own firing profile with multiple ramps & holds.

Brick. Skutt kilns are constructed of the finest insulating firebrick available today, offering strength, cleanliness and long life. All bricks are precision cut and grooved to assure tight fit, perfect element support and ease of replacement. Because of their porous composition, insulating fire brick are fragile. Always handle your kiln and its brick with care. The brick in your kiln may begin to show some fine cracks after the first few firings, especially after Cone 10 high firings. This is normal and does not harm the structural integrity of the kiln or impair its functioning.

Elements. The highest quality iron-aluminum-chromium (Kanthal-type A-1) element wire is used in all Skutt kilns.

Element life will vary depending on whether the kiln is used primarily for low firing of bisque or greenware, or high firing of stoneware and porcelain. Elements will last for many firings if treated carefully.



Remember these points.

1. Keep the element grooves free of debris: bits of bisque, glaze, cones, metal or high fire kiln wash will immediately fuse to an element and proceed to eat through it. Kanthal elements become brittle after repeated firings, so be extremely careful not to scrape against them.
2. Do not attempt to fire beyond the rating on your kiln.

Stainless steel jackets. Only the finest grade stainless steel is used in Skutt kiln jackets, selected for its expansion qualities so that the bricks are never unduly stressed, yet are fully supported during all stages of heating and cooling. Stainless steel may discolor with repeated heating. Stainless steel cleaner is available.

Lid brace. The lid brace holds the lid securely open for loading and unloading the kiln. As you open the lid, allow the lid brace to follow over the anchor pad and screw that is attached to the side of the kiln. Simply allow the notched end of the brace to engage the anchor pad and screw, allowing the lid to rest in a full upright position. Periodically test the thumbscrew for tightness. If loose, tighten.

Modular design. Larger Skutt kilns use stackable ring segments which makes them easier to move and allows better access to elements and firebricks.

The Wall-mounted KilnMaster Controller.

The wall-mounted KilnMaster functions in the same manner as the kiln-mounted version with the exception that it can be moved from one kiln to another. While the wall-mounted version cannot fire more than one kiln at a time, it can control virtually any kiln in a studio which has the proper cord plug and receptacle configuration.





The Wall-Mounted KilnMaster Controller

The wall-mounted KM-1 KilnMaster gives automatic kiln control to most modern Skutt 208/240V kilns and any other brand kiln which uses NEMA 6-50 (single phase) or NEMA 15-50 (3 phase) plugs and receptacles. It can control virtually any kiln in a studio which has the proper cord plug and receptacle configuration.

Once installed, the KilnMaster controller uses the same operating instructions as other Skutt Automatic kilns.

Locating the controller. Pick a location that will put the controller *at least* two feet from the kiln to prevent overheating the controller.



Mounting the controller on the wall. Mark the hole positions on the wall where the controller will be installed using the paper template supplied with the controller.

To mount the controller on stud or post:

1. Use the holes marked "A" on the template and screw a #12 x 2" wood screw into the wall leaving a 1/8" gap.
2. Repeat for the second screw.



To mount the controller in sheet rock:

1. Using holes marked "A" and "B" on the template, drill the necessary holes to properly mount the 1/4" x 2" molly bolts into the sheet rock.
2. Tighten the first bolt until there is a 1/8" gap.
3. Repeat for the other three molly bolts.

Before hanging the controller on the wall, loop the cord attached to the quick reference card over a screw so that it hangs below the controller when mounted.

CONNECTING TO THE KILN.

Single Phase. (Switching capacity 48 Amps on 208-240V) To operate the wall-mounted controller, simply engage the kiln plug in the receptacle located on the back of the controller. Then plug the controller into the existing wall receptacle.

Three-phase. (Switching capacity 40 Amps on 208-240V) To connect your three-phase kiln, plug the power cord from the kiln into the receptacle mounted on the back of the controller as shown below. Plug the pilot cord (the smaller cord) into the small receptacle mounted on the underside of the controller. The





controller is plugged into a wall receptacle which provides three phase voltage.

You will no longer need to use the three-phase contactor box. However, an electrician may need to wire a receptacle for the controller if a three-phase contactor box was used previously. You may need to make other changes to the supply for kilns not made by Skutt. Other manufacturers may not use pilot cords. Please discuss this with your distributor.

Thermocouple mounting. Skutt kilns have a hole stamped in the stainless band where the thermocouple flange should be mounted. This hole is located to the right of the red switch boxes. You can see the firebrick through this hole. The thermocouple flange is a metal tube approximately 5/8" in diameter and 1 1/2" long attached to a metal washer.

1. Remove the thumbscrew from the flange.
2. Align the thermocouple flange so that it is exactly over the hole in the stainless band. Position the flange so the thumbscrew is on the top. Attach the flange to the kiln using the two Phillips self-tapping screws provided. Note: To start the screws, lightly hit each screw with a hammer until the point has pierced the stainless steel band.
3. Insert a 1/4" twist drill or carpenter's bit through the flange holder. Slowly drill through the kiln wall brick into the kiln chamber as shown at right.



4. Insert the thermocouple into the kiln so that 1-1/4" to 1-1/2" of the tip protrudes into the kiln chamber. Tighten the thumbscrew.
5. Uncoil the yellow thermocouple wire that is hanging from the bottom of the controller enclosure. Next, take the receptacle on the end of the wire and engage it with the two prongs on the thermocouple which you mounted on the flange in Step 4. There is only one way the plug will engage the receptacle.
6. The controller is now ready for use.

If you are installing the thermocouple on a kiln that is not marked for a thermocouple, please follow these instructions.

1. Mark a 1/2 to 5/8" diameter hole on the stainless jacket in the center of the brick next to the Kiln-Sitter brick (one brick to the right of the master switch-box). Be sure placement is accurate so that you do not drill through an element. *Do not drill yet.*

2. Align the flange holder accurately over the mark, positioning the thumbscrew hole on top. Mark the position of the small holes on the jacket. Push hard or tap out with a nail and hammer the small screw holes. Drill two 3/32" holes for the smaller sheet metal screws. Drill through the *metal* only. Install the flange with the sheet metal screws provided.
3. Follow steps 2-6 above.

KILN SETTINGS

The kiln switches, Kiln-Sitter and limit timer (if so equipped) need to be properly set and adjusted for correct operation with the controller. Please follow the instructions for the option(s) that apply to your kiln.

Kiln-Sitter. The Dawson Kiln-Sitter is no longer a control device when used with the KilnMaster controller, but it can be used as a backup safety device.

1. Place a Junior cone one or two numbers hotter than the cone equivalent you program into the KilnMaster to keep the Kiln-Sitter from shutting off the kiln early. For example, if you program a Cone 5 (2156°) firing in the KilnMaster, place a Cone 6 or 7 Junior cone in the Kiln-Sitter. Use your firing experience or read the relevant sections of this manual for more information.
2. Push the plunger in. Repeat this procedure using new cones each firing.

Limit timer. If your Dawson Kiln-Sitter is equipped with a limit timer, set the timer

for 20 hours (the maximum). Because the KM-1 controller turns the power to your kiln on and off to control the temperature, the timer will only run intermittently and will be useless. If you fail to set a maximum time each firing, the timer may shut off the kiln early. You may want to disconnect the wires that operate the limit timer to eliminate the bother of resetting the timer each firing.

Switches. The switches on your kiln will no longer be used to control the temperature rise inside your kiln. The KM-1 controller now controls the heating rate.

Set all switches in your kiln to High. (Exception: do not set the center section of the 818-WR above 4.)

If you have questions, please call Skutt Ceramics at (503) 774-6000.

Programming. Refer to the Quick Start sections on Cone Fire and Ramp/Hold for instructions on programming.

WALL MOUNT CONTROLLER

The KilnMaster contains many components which cannot be replaced in the field. Your Skutt distributor may be able to replace cords, connectors and relays.

The thermocouple can be easily replaced when needed:

1. Loosen the thumbscrew on the thermocouple flange and gently pull the thermocouple assembly out of the kiln.
2. Discard the old thermocouple and plug



a new MI cable thermocouple into the receptacle mounted on the cord from the Wall Mounted Controller.



If a problem persists, call the factory to make arrangements for return of parts. When the controller is received we will evaluate the problem and call you with a cost estimate.

Send to Skutt Ceramic Products, 6441 S.E. Johnson Creek Blvd., Portland, Oregon 97206-9594. Our telephone number is (503) 774-6000, Fax (503) 774-7833.

See page 35 for details on replacing the thermocouple elements on KM kilns, which have a slightly different mount.

Automatic kiln set up.

PLANNING THE LOCATION OF YOUR NEW KM-SERIES KILN.

Location. For safety and convenience follow these basic rules.

1. Locate your kiln near your present electrical outlet or where a new circuit can be installed with least cost. Position the kiln to the left of your electrical outlet so the cord will have an easy run and will not place a strain on the plug or outlet.
2. Install it in a well ventilated, sheltered area such as a carport, garage, utility or hobby room. It should be convenient to your clay working area, and out of the way of other traffic.
3. Allow at least 18" of space between your kiln and adjacent walls.
4. Keep curtains, aprons, plastic or other flammable materials away from your kiln.
5. Never fire your kiln within a four sided cabinet or closet. The fourth side must always be open to room air to prevent the kiln from overheating surrounding surfaces. It is best to leave at least two sides open for easy access to controls and peep holes. Fully automatic kilns should not be located in a room that exceeds 105°F (41°C) or is less than 32°F (0°C) as damage to the electronic components may result.

6. Always locate the kiln on a non combustible floor such as cement or ceramic tile.
7. When installing a kiln in a room with a fire control sprinkler system, please check the sprinkler head rating to insure that heat emitted from the kiln will not activate the sprinkler system.

UNPACKING AND CHECKING THE KILN

Checking your kiln for damage. Your kiln has usually traveled a long way by rail car or truck to get to you. Even though it was carefully packed at the Skutt factory, it could have been mishandled in shipping. If you find any problems as you unpack, do this.

1. Call your freight agent and ask for an inspection.
 2. Save all the packing materials.
 3. Contact the dealer where you bought your kiln.
 4. Don't assemble or fire your kiln until your damage claim has been inspected.
- Fortunately, few Skutt owners will experience any problems.

For information on setting up Skutt PK Production Kilns, see Appendix 7 beginning on page 45.

Unpacking the kiln.

1. The bottom tray of each carton is attached to a wooden pallet. The kiln rests on foam packing material which is on the bottom tray. The bottom portion of the carton is stapled to the tray. After removing the staples from the tray, the carton can lift straight up exposing the assembled kiln. There is foam packing material that will fall loose from the kiln when the carton is lifted. Remove the plastic sheet and paper shields.
2. Open the lid, remove the plastic cover and carefully remove the kiln stand and "goodie bag" from the inside of the kiln. Close the lid.
3. For larger, heavier kilns you may choose to remove the lid from the top section. This will reduce the overall weight. To do this remove one cotter pin from the lid rod and slide the lid rod out of the lid hinge assembly. Also remove the thumbscrew and lid brace. Place lid on a clean, flat surface.
4. Remove the black plastic feet from the "goodie bag" and put them on the stand legs. Set the stand in the location you have designated for the kiln. See the section on locating your kiln if you are not sure about the safety requirements for the kiln site.



6a



6b

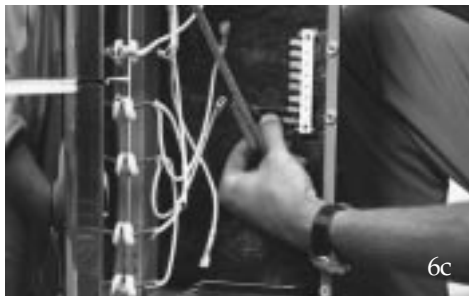

6c



5. There are section handles on the kiln. With a partner, lift the kiln, using the lower section handles, off the kiln floor and rest on a clean, flat surface.

6. You may separate the kiln into sections if it is too heavy to move.

a. The electronic control panel of your kiln has a hinged box for easy removal. Remove the screws on the left side of the box that secure the box to the kiln.

b. Swing the panel to the side.

c. Slide the connectors off of the terminals noting the placement of the wires. Slide the thermocouple connectors off the terminal strip, also.

d. Lift the box up to remove it.

7. Position the kiln floor on top of the stand making certain that the weight is evenly distributed.

8. Level the kiln. Make sure the stand and kiln floor are level and do not teeter. Leveling problems may put unnecessary stress on the kiln during firing. To level the stand, place firm shims under the legs (never above them touching the kiln). Center the kiln's bottom slab on the stand and double-check teetering.

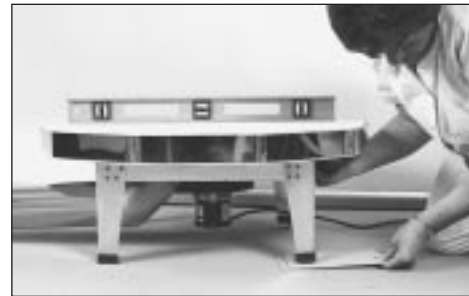

9. Again, with a partner, pick the kiln up and rest it on top of the kiln floor.

10. Replace the kiln control box on the kiln if removed in step 6 above.

a. Stack the sections on the kiln floor.

b. Return the kiln control box to the side of the kiln.

c. Slide the connectors back into place. Plug thermocouple in.

d. Close the box and secure it with screws.

If the lid was removed in step 3 above, place the lid on top of the kiln, replace the lid rod and cotter pin and the lid brace and tighten the thumbscrew.

11. Place peep plugs in all but the top peep hole. Always leave the top peep hole open to allow vapors to exhaust from the kiln *unless* you are using a fan-driven ventilation system such as the Skutt EnviroVent®. The EnviroVent allows you to fire with all peep hole plugs installed.



ELECTRICAL REQUIREMENTS

Most important to proper operation of your new kiln is to make sure it has enough of the correct power to operate it. If this is done, your kiln will give you years of satisfying service; if not, your first firing could be disappointing or even disastrous for your kiln. The chart at right shows the recommended electrical specifications for each kiln model. If you are uncertain about your existing outlets, have them checked by an electrician. If you are installing a new receptacle, have the electrician follow this guide.

ADDITIONAL POWER NOTES

Three-phase operation. Only special order Models KM-1027 and KM-1227 will operate on a three-phase supply. However, any Skutt kiln can be properly powered via unbalanced connection to two of the three hot wires of a three-phase supply. Of course, the green safety ground connection provided in all Skutt power cords is also used.

Three-phase installation. Three-phase Models KM-1027 and KM-1227 can be plugged directly into a three-phase (15-50R) wall receptacle.

208 versus 240 supplies. As you can see from the chart, most Skutt models are available in either 208 or 240 volt versions.

Electrical requirements for Skutt Automatic Kilns and KilnMaster Controller

Model	Volts	Amps	Watts	Copper Wire Size*	Fuse or Breaker Size	NEMA Receptacle Configuration
KM-614-3	115	20	2300	10	30	(Canada) 5-30
KM-614-3	115	20	2300	10	30	5-20
KM-714	208-240	20	3600	10	30	14-30
KM-818	240	27.8	6400	8	40	6-50
KM-818	208	26.7	5550	8	40	6-50
KM-818-30A-3	240	21.7	5200	10	30	6-30
KM-818-30A-3	208	24.0	4990	10	30	6-30
KM-1018	240	38.4	9460	6	50	6-50
KM-1018	208	40	8320	6	50	6-50
KM-1027	240	48	11520	6	60	6-50
KM-1027	208	48	9980	6	60	6-50
KM-1027 3ph	240	29.3	11520	8	40	15-50**
KM-1027 3ph	208	31.7	11000	8	40	15-50**
KM-1227	240	48	11520	6	60	6-50
KM-1227	208	48	9980	6	60	6-50
KM-1227 3ph	240	29.3	11520	8	40	15-50**
KM-1227 3ph	208	31.7	11000	8	40	15-50**
KM-1	208-240	Switching Capacity			48	6-50
KM-1 3ph	208-240	Switching Capacity			40	15-50

**For each additional 50 feet use heavier wire, numerically two numbers lower—for example, instead of #10, use #8. If you anticipate installing any larger kiln in the future, use the heavier wire.*

***See special instructions and wiring diagram.*

The exception is Model KM-714 which is universal, and will fire with 240V or 208V power.

The “120/208V” supply is increasingly encountered in schools and newly-built communities, because it’s more efficient for heavy 120V loads.

The 208V versions should never be fired on a 240V supply without first installing a full set of 240V elements. Otherwise, all components will be seriously overtaxed. Conversely, a kiln designed for 240V supply which is powered on a 208V supply will be severely underpowered.

Important! Connecting and testing Model KM-714. The wall outlets for Model KM-714 must be powered by 3-wire 120/240-208V solid neutral supply—as for an electric range. Only No. 10 wire is required (or No. 8 for runs over 50 feet). 30 Amp fuses or circuit breakers only—no larger or smaller—are recommended. The U-shaped fourth blade of the 4W30 Amp grounding plug is for the pure green wire grounding of the kiln case. The blade opposite this U-shaped one takes the white solid neutral wire. See the diagram below and refer to the wiring diagram in Appendix 5 for the 714 plug diagram.

NEMA RECEPTACLE GUIDE.

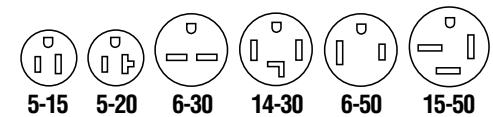



PREPARATION BEFORE FIRING

Remove any brick chips or other foreign matter from around the elements. Bits of bisque and glaze will eat through elements and our warranty cannot cover such accidents. We recommend that you vacuum the inside of the kiln to remove any dust that accumulates during shipment.

Wipe all new shelves clean, and brush coat one side of each with high fire kiln wash. Apply a thin coating of kiln wash in one direction, allow to dry and apply another thin coating in the opposite direction leaving a 1/2" margin from the outside edge of the shelf. A new coat is seldom needed—just spot-patch and sand off the surface evenly with coarse sandpaper wrapped around a wooden block. A fresh coat may be needed before a porcelain firing if glaze has dripped onto the shelf.

Kiln wash the floor of the kiln, being careful to leave a one inch margin unpainted all the way around interior edge. **Never kiln wash the walls or lid of your kiln!**



THE IMPORTANT FIRST TEST FIRING

Now you're ready to fire. Be sure to review the preceding sections, double checking for safety and correct electrical connections.

It is important to the life of your kiln that your first firing be done properly. Before you start, read this entire manual carefully, including the preceding sections and loading and firing instructions.

New elements and foreign matter like dust give off vapors that tend to discolor glazes. Therefore, your first firing should be a Cone 04 *empty* test fire with only your dry shelves in the kiln, posted as though ware were on them. The first time the elements are fired they will give off some smoke. This is normal and expected. This is a good time to use Self-Supporting Cones on the shelves to test the heat accuracy from top to bottom.

A Cone 04 (1944°) is recommended for proper pre-oxidation of a new element. The steps to accomplish this firing are the following:

1. Clear the **PF** message by pressing **Enter**.
2. Press **Cone Fire** mode.
3. Press **0 4** then **Enter**.
4. Press **Medium** speed then **Enter**.
5. Press **Enter** or an amount of time in hours and minutes for **Hold**.
6. Press **Start** to begin the firing. The firing will take approximately 7 1/2 hours.

Even though you have gone through a simple program for a test firing, please continue to read the detailed instructions in the Cone Fire and Ramp/Hold sections of this manual.

Periodically view your Self-Supporting Cone by removing a peephole plug. It should bend to the top of the base (5 o'clock position) and the kiln should turn off about the same time. Watch your kiln throughout the firing. Don't rush through the first firing. Make notes of things that you want to remember and make visual observations of the kiln while it is firing.

Likely, everything will work as it should, and you're ready to go on to production firings. If things go wrong, re-read this manual and contact your Skutt dealer.

You will notice a clicking sound while your kiln is firing. This is normal. The elements are cycling on and off to stay within the temperature parameters you have programmed.

After the first couple of firings, hairline cracks may appear in the floor of a kiln. This is caused by the expansion and contraction of the bottom slab caused by heating and cooling, and is considered normal. It will not affect the firing of your kiln nor the life of the kiln floor.



General Ceramic Information

PYROMETRIC CONES

Ceramic firing to the accuracy we know today would be impossible without pyrometric cones. These long tetrahedrons of controlled composition measure the combined effects of time and temperature accomplished during a firing. Please refer to Appendix 2 which further describes the theory of heat work. The KilnMaster Controller uses the patented Orton process of time and temperature when in the Cone Fire mode. Even though you are operating a fully automatic kiln, you still need to verify the temperature on the shelf using Self-Supporting Cones.

Senior Cones are designed to be placed standing in angled holders or Commercial cone plaques or Self Supporting Orton Cones. We recommend using the Self-Supporting Cones that have a precise 8° angle built into the base allowing the cone to bend properly. When the cones soften and bend to the top of the base (90° is perfect), the correct firing time and temperature have been reached. It is important

that the cone is standing at the proper angle (as precut at the base) for it to bend at its standard temperature.

Obviously, if you wish to monitor firing progress, Cones must be visible through a peephole.

The traditional and still the most accurate method of monitoring a firing is to use three Self-Supporting Cones: the one called the guide cone should be one number cooler than your desired firing; the firing cone should be the desired heat, and the guard cone should be one number hotter as shown below in a typical example.

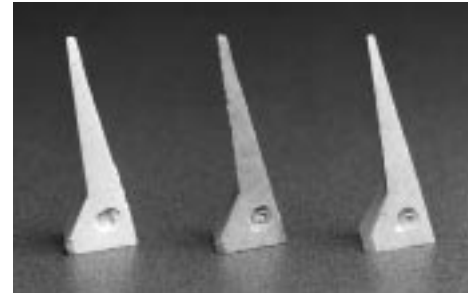

As your firing nears maturity, the guide cone will bend or “drop”. This alerts you to watch the firing cone. If the guard cone is not straight, the best heat work has been exceeded.

If you discover that your automatic kiln is underfiring ware, check the load in your kiln to ensure that it is evenly distributed from top to bottom. It is easy to program a 5 to 10 minute hold at the end of your Cone Fire. The hold can be preprogrammed or added at the end of a firing schedule. See Cone Fire mode for detailed instructions.

Cones are sensitive to moisture when stored and to drafts when firing. Keep them dry or invisible cracks may develop, causing early bending. If you have a cone problem, try fresh ones from another source. Place cones at least 3” back from peepholes to avoid a false response to cool air.

At high temperatures cones can be hard to see. Viewing through dark glasses can help. Try to keep ware back from cones as far as possible to avoid a cone melting into the ware.



PRECAUTIONS

The controller is a temperature control device. It is not a safety device.

The maximum operating temperature is 105° F (41° C). This temperature refers to the room temperature and does not pertain to internal temperature of the kiln.

The minimum operating temperature is 40° F (4° C). See page 15 for cold kiln room recommendations.

The controller contains static-sensitive parts that may be damaged by static electricity. Use caution to avoid creating static that may damage the equipment. In areas where static electricity is common, or during dry times of the year throughout the country, touch the kiln lid handle before touching the controller to discharge the static.

Never leave the kiln unattended at the end of the firing.

LOADING:

THE KEY TO CONSISTENT RESULTS

If this is the first firing of the kiln, or if you have just replaced the elements, please fire the kiln empty to Cone 04.

Careful loading will always be repaid with satisfaction. Rushed, careless loading can bring disaster to pieces you've worked on for hours.

First, never load damp ware into your kiln! Make sure it's all bone dry first.

Keep a piece of old greenware on your drying shelves. New ware should feel no cooler on your cheek or forearm than an old piece. If it does, water is still evaporating from it.

Plan your load carefully. Set out all your pieces before you start loading, and pre-arrange them as you would to load them. Always load slowly—dropped ware on shelves may damage the inside of your kiln.

Balance out your load by density. If half your load consists of small, heavy pieces, and half of large thin-walled pieces, don't group the small heavy pieces in one section, but mix them so there is a balance of each type throughout the kiln. See the photos at right. Don't set pieces of ware directly on the floor of the kiln. The first shelf should be 1" off the floor of the kiln. For best results ware should not be placed within 1" of the elements. If possible, place ware so that an element groove is under the shelf.

Don't place ware too close to the thermocouple. We recommend keeping ware and shelves at least 2" away.

Large flat pieces like plates that demand the full width of the kiln should have their rims positioned between two elements. We recommend placing a Self-Supporting Cone in every firing. Although you normally won't watch it go down, its condition when you unload the kiln will prove your firing was correct—or alert you to possible problems if the ware displays faults.



GREENWARE FOR BISQUE FIRING

Greenware is easier to handle and load than other ware. Greenware should be placed in the kiln in its natural position, but any large flat piece—such as a wall plaque—can go on its flat side to prevent warping. Canisters and boxes should be bisque fired with lids in place for assurance of good fit. For more efficient production, you may wish to experiment with nesting bisque, as shown below. Just remember, never strain the rims.





GLAZE FIRING

Glaze firings require that you have kiln washed the bottom of the kiln and one side of each shelf. Glaze will stick permanently if you fail to keep a good coating of kiln wash on these surfaces.

Don't let any of your pieces touch one another or the side of your kiln.

Stilts are devices used in glaze firing to elevate the fired pieces from the shelves.



There are many styles. Use those that provide the widest bearing capacity for stability. If a piece wobbles on its stilts, it may tumble during firing. Make sure you have a good solid base.

"Dry-footing" a glazed piece will eliminate the need to stilt your ware. To dry-foot, avoid glazing the base of your piece. Or you can apply wax resist to the base which will cause the glaze to puddle up, making it easy to remove with a damp sponge. Any part of the ware that will touch the shelf cannot have glaze on it.

Leave all possible breathing room between pieces for best firing uniformity. Ware should be at least 3/4" apart on the shelf or bubbles and fumes may contaminate adjoining pieces.



PORCELAIN AND STONEWARE FIRINGS

These materials differ only in purity of clays, although they appear different in color and texture. By definition, both must be fired hot enough to render the bodies waterproof (or vitreous) at which temperatures they tend to wilt.

Because the bodies become soft, they must be bisque and glaze fired resting flat on a freshly kiln washed surface, or one sprinkled with silica flour (flint). Flint must be kept out of the element grooves. Remember to vacuum the grooves periodically.

Be sure to check clearance at the top of your porcelain load with a ruler so that pieces do not touch the lid and stick to it.



To avoid distortion, pieces must either be carefully designed or the overhangs specially supported. Figurine arms are generally supported by hollow greenware pillars, made of the same clay material. These will shrink along with the piece, which in high firings can be as much as 12 percent.

Simpler shapes such as wide plate rims are generally supported by reusable rings (setters) made of even higher firing material specifically shaped for that one article.

Both porcelain and stoneware glaze firings are dry-footed to prevent fusion to the shelves.

OVERGLAZE FIRINGS

Stilting may be helpful because it allows heat to penetrate between the ware and the slower-heating shelves. Large double-pointed stilts can be used to hold plates apart when fired on edge.

GLASS FUSING AND SAGGING FIRINGS

When firing with more than two shelves, the lower one is usually posted well off the kiln floor and the upper one is placed at least 3" above the first mold. The center of the load should fall a bit above the center of the kiln.



General Firing Information

When firing a new kiln or one that has undergone repairs or disturbance, place and watch a Self-Supporting Cone at three levels within the kiln chamber.

If you are ever in doubt about a firing, simply **press STOP or unplug it**. Never chance ruining an entire load of ware if something has toppled off its stilts, if you hear odd noises, or if the kiln has been jarred. You won't harm your ware by shutting the kiln off before maturity. Simply set fresh Self-Supporting Cones on the shelves and begin again. (If you're firing with a KM-1 wall-mounted controller, replace the Junior Cone in the Kiln-Sitter each firing.)

Because you will keep the top peephole unplugged during the entire firing, **never** unplug any of the lower peepholes for more than a few seconds. This causes a strong convection "jet-draft" which can easily fracture ware and chill the cones in the kiln, particularly visible cones placed behind that particular peephole.

To determine the adjusted end firing temperature in Cone Fire Mode, press **Enter** to get a blinking temperature, then press **Review**. (In Ramp/Hold Mode, this procedure will flash back the program just fired.)

PRE-FIRING CHECKLIST

Load kiln.

- ❑ Set Self-Supporting Cones while loading. See loading instructions for more detailed information.

Kiln ventilation.

- ❑ The lid needs to be propped 2 1/2" until the internal temperature of the kiln reaches approximately 1000°F, at which time it is lowered.
- ❑ If you are using a positive kiln ventilation system such as the Skutt EnviroVent, the lid does not need to be propped and peep hole plugs remain in place throughout the firing. Refer to the EnviroVent instruction manual for complete details.
- ❑ Suggestion: You may wish to place a final kiln shelf on posts above your load to deflect any cool air coming in from the top of the kiln



- ❑ Before firing, plug peepholes except the top one, which is always left open. This will allow fumes to escape. (Not necessary when using the EnviroVent.)



Firing speed.

- ❑ Keep in mind the heating rate for each of the speeds: slow, medium and fast. Consider that the best firing time is from 6-8 hours for a Cone 04-06 bisque or glaze firing.
- ❑ Using this information, program the kiln for the firing cycle that best suits the ware you are firing. See *The KilnMaster Controller* section for detailed information regarding programming.

Wall mounted controllers.

- ❑ Kilns with a limit timer need to be set for 20 hours when operating with the KilnMaster controller.
- ❑ Use a Junior cone one to two cones hotter in the Kiln-Sitter as a backup for the controller. See the section on the Wall Mounted KilnMaster Controller for more specific information.

Caution:

While the KilnMaster has an excellent operating record, **we recommend that you do not leave the kiln unattended during firing.**

COLD WEATHER OPERATION

While it is possible to operate a KilnMaster-controlled kiln in cold weather, the relays which must open and close freely can tend to stick at low temperatures.

We recommend that your work space be heated to at least 40° F for proper KilnMaster operation.

If the temperature in your kiln area is near or below freezing (32° F), use a space heater or hair dryer to gently prewarm the controller box and thermocouple to 40° before starting the firing program.



TYPE OF FIRING

This section gives you some useful tips for various types of firings. Please keep this information in mind as you program the KilnMaster.

Venting.

The use of a positive flow downdraft kiln ventilation system such as Skutt's EnviroVent pictured at right keeps the lid down and all peep hole plugs in place throughout the firing. This will provide many benefits, such as:

- a healthy work environment by removing fumes from work area
- more even heat distribution from top to bottom of kiln
- less color migration between glazes
- eliminates the necessity to lower the kiln lid during firing
- improves the end firing results of red glaze.

The most convenient feature is not having to lower the kiln lid during firing.



Underglaze firing.

Greater detail can be preserved in conventional and one-stroke underglaze decoration if it is first set by an 019 firing before glazing and then glaze firing. If the decoration was applied directly to greenware, the underglaze fire acts as the bisque, and therefore should be a full Cone 04 firing.

Ceramic glaze firing.

Warning: Use only lead-free or lead-safe glazes on any surface which may come in contact with food or drink.

If your ware has been fired to Cone 03 or 04 and is properly glazed, dried, and loaded, an 06 or 05 low glaze fire or 6 to 10 high fire will normally produce a flawless surface. If not, consult the ware imperfections section of this manual.

Crystalline glazes often require special firing to develop fully—including a soaking period at slightly reduced heat after maturity is reached. Experimentation is generally needed to discover the correct amount of soak time and correct soak temperature for your glaze formulation. Once your firing schedule is perfected, store it in permanent memory in Ramp/Hold mode.

“Greenglaze” one-fire ceramics

With the talc clay bodies and prepared glazes available to the ceramist today, some prefer to “one-fire” their ceramics. In some instances you can satisfactorily glaze a piece of greenware and complete it in a single firing, maturing the clay body and the glaze at the same time. However, because there may always be residual moisture in the clay body, persistent cratering and pin holing may occur, as well as off-color spots from impurities burning out of the clay. Fire to at least Cone 05, or preferably to Cone 04.

Overglaze fires.

China paints. If fired too hot, fine detail will be blurred. If fired too cool, china pigments will not be absorbed into the glaze and will quickly wear off. Fire until the paints acquire a sheen similar to the surrounding glaze. With practice, this can

be judged through the peephole. By setting a group of guide cones, you can note which cone is down when the sheen matches, so you can program exactly to this cone the next firing.

This temperature will vary over several cones if widely different colors are used. High quality will be achieved only by applying and firing the higher temperature colors first, followed by lower temperature ones. The required temperature also varies with the softening temperature of the parent surface.

For ceramic and porcelain articles other than tableware, a single Cone 019 firing will often be a good compromise.

Metallics (gold, platinum, copper, and other). These will fire dull if applied too sparingly, or if underfired. Overfiring, particularly of larger areas, results in reticulation or “crocking”—shrinkage of the metal, leaving a network of glaze lines exposed. Greater overfiring results first in spotty, then total disappearance of metal through vaporization. On ceramics and porcelain start with Cone 019. Metallics and green glaze are usually incompatible.



Lusters. Luster may flake off if applied thickly and will “frost” if overfired. To start over, fire to 06-05. Keep ware well away from kiln elements. Fire to 019 for durability, drop to 020 if frost is encountered. Lusters are extremely sensitive to contamination by kiln vapors, particularly those from greens, and lid ventilating must sometimes be continued at 1/2” or 1” throughout the firing.



Overglaze. Breakage of ware during overglaze firings can usually be traced to roughly-handled, unevenly-dried or unevenly-sponged greenware. In general, there is less trouble with art porcelain than with ceramic pieces, and least with high quality, pre-glazed, dry-footed imported china blanks.

Firing schedules for overglazes can usually be accelerated because the ware is entirely free of moisture. A fast firing rate will be appropriate for this type of ware. The lid remains propped until the odor from the burning medium is no longer detected. Under-ventilation is the biggest cause of problems. Of course, if you are firing with an EnviroVent, this will not be a concern.

Firing porcelain.

Art porcelain should be bisque fired to Cone 5 or 6 (not 05-06) in your Skutt kiln unless glaze is to be applied, in which case a soft 05 or 06 non-vitrifying fire is appropriate. Ware should be loaded and sup-



ported as noted in the loading instructions. Begin lace fires with the lid posted open 2 1/2”. Optimum quality can be achieved several ways:

1. By not loading the kiln very heavily with ware or extra shelves.
2. By bisque firing twice; one to the firing temperature of the clay, and another to one cone equivalent cooler. Wet-sanding with a fine grit silicon carbide paper between firings will maximize smoothness in the finished piece.
3. “Soaking” for 30-45 minutes slightly lower than the maturing temperature will add sheen to the porcelain. The process for soaking is discussed in the section about glaze firing.

Porcelain glaze is usually fired to maturity of the clay and dry-footing is still essential.

Overglaze decoration is fired exactly as with ceramics, but usually 2 to 4 cones hotter (017-015) to produce penetration, gloss and durability on the higher-softening glaze. Overglazes are also frequently applied directly to porcelain bisque that is to remain unglazed. Fire to the above cones.

Firing stoneware.

Most Skutt kilns (except a few 208V models and KM-614-3) can attain Cone 8 or Cone 10. Because stoneware shapes are designed for self-support during firing, the glaze can be matured at the same time as the body, particularly because the pinholes, sunbursts and scumming which tend to accompany one-firing are often highly prized in stoneware. Pieces are dry-footed, of course, and loaded as previously described.

The procedure for stoneware differs from that for one-fire ceramics in that the plain or decorated greenware is usually first given a low bisque firing to Cone 016-04 before glazing. Due to the ware’s thickness, the firing rate must be much slower and more prolonged than in other types of ware.

While the typical overglaze decorations are rarely considered suitable on stoneware, Cone 06-04 reds, oranges and crackles are sometimes added after firing to provide effects unobtainable at the higher temperatures. Warm (130°F/54°C) the vitrified ware to facilitate application of glaze.



Firing glass.

Sagging of sheet glass and bottles is carried out in terra cotta molds dusted with whiting (calcium carbonate) or one of several similar tradename separators. Use the Ramp/Hold Mode for glass sagging. This will allow you to program your own specific rate of climb and hold temperatures.

Glass decoration can often be carried out with conventional china paints, metallics, and lusters when the glass is being fired to sagging temperatures. Freestanding tumblers and other vessels can rarely be taken above Cone 022 without wilting, so at such low temperatures the special glass stains, golds and lusters produce more dependable results.

Quick Reference Chart

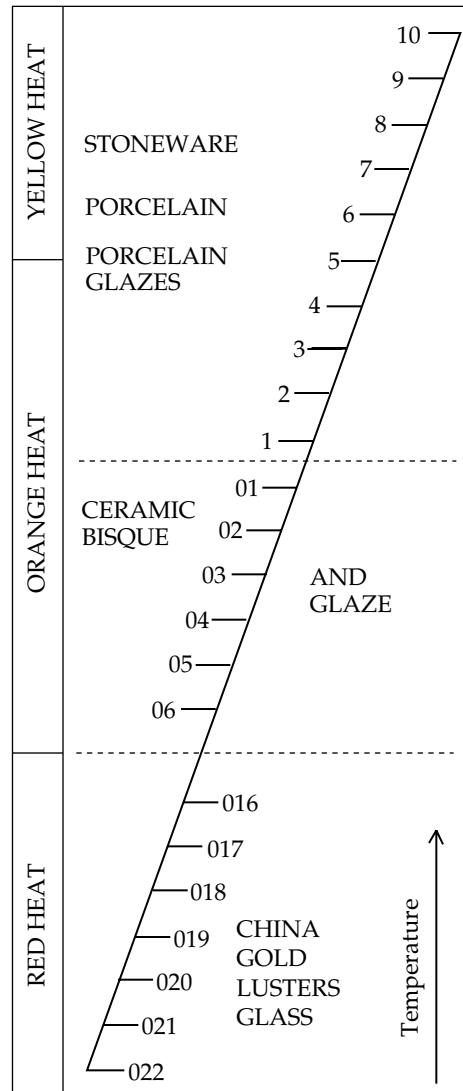

The KilnMaster Controller

DURING THE FIRING.

What you'll see is the internal temperature of the kiln displayed in the window of the controller as the temperature increases. The options available during the firing are:

- **Review** program at any time.
- **View** Current Segment of Ramp/Hold Program.
- Press **Stop** to interrupt a firing for any reason.

Please refer to the Key Functions section of the manual for detailed explanations of the functions.

AFTER EACH FIRING.

1. When the firing is completed, the display will alternately indicate "CPLT" for complete and show the firing time in hours and minutes. Press **Enter** to display the current internal temperature. In Cone Fire Mode, the KilnMaster will adjust the shutoff temperature to correspond to the actual heating rate the kiln can achieve. This may or may not be the programmed value. To see the adjusted value, press **Review** immediately after activating the touch pad.
2. Allow the kiln to cool naturally. Never unplug other peepholes or post the lid until the ware is cool enough for bare-handed unloading, about 130°F.
3. When unloading, be sure to examine the Self-Supporting Cones on the shelf to determine if the kiln is firing correctly.



Cone Fire Mode

Description

The Cone Fire mode is extremely easy to use but gives you access to many advanced features. You only have to enter three pieces of information—cone number, speed, and hold time. Cone values range from Cone 022 through Cone 10. Entering a cone number causes the controller to look up the final temperature in a 108°F/hr Cone Table. You have three speeds to choose from, slow, medium, or fast. The speed chooses a ramp profile as described below. Also, the Cone Fire mode allows you to specify a hold time at the final cone temperature. It is also possible to program a preheat or “soaking” period to insure all the moisture is eliminated from the ware prior to running the full program.

The Cone Fire mode uses a method patented by The Edward Orton Jr. Ceramics Foundation that measures the rate of firing during the last hour of the firing and adjusts the final temperature to the correct cone temperature based on the observed firing rate. This will insure consistent results as the kiln elements become weaker with normal wear from repeated firing.

PROFILES

Cone Fire—Slow

Slow is for hand thrown pottery, porcelain, and stoneware. The firing will take 12 hours* to complete. If you were to program the segments for this firing, they would look like the chart at right; however, they are automatic.

The graph at right illustrates the segments of a cone 04 firing in Cone Fire mode, slow speed. The firing will take approximately 12 hours to complete. The heating rates are the same for all cones. The temperature in segment 4 is 250° less than the final temperature for the cone.

**Firing times are approximate, based on a beginning temperature of 70°F/21°C firing to Cone 04.*

Segment	Rate	Temperature	Hold
1	80°/hr	250° F	0
2	250°/hr	1000° F	0
3	150°/hr	1300° F	0
4	180°/hr	1685° F	0
5	80°/hr	1938° F	0

Cone 04, Slow Speed

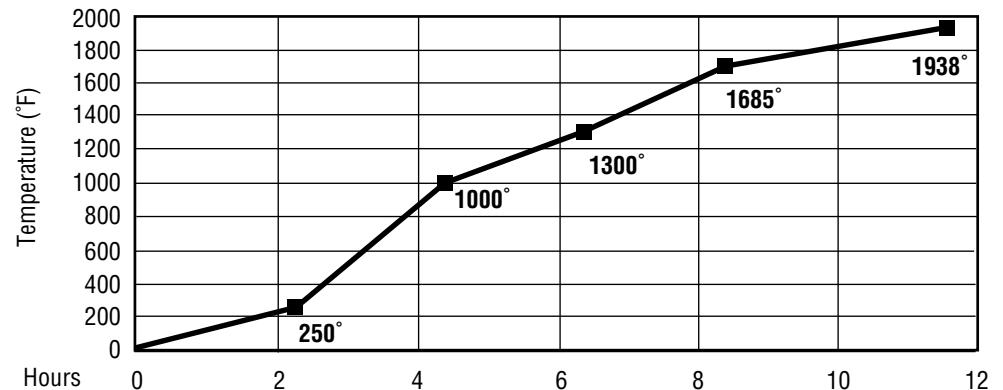



Cone Fire–Medium

Medium is the speed you will probably use for your firings of cast earthenware and low-fire glazed pieces. It will take approximately 7.5 hours* to fire. The actual time is dependent on the selected cone value. Use this speed when the kiln is packed tighter or your greenware has thicker sides or a higher moisture content. If you were to program the segments for this firing, they would look like the chart at right.

The graph at right illustrates the segments of a cone 04 firing in Cone Fire mode, medium speed. The firing will take approximately 7.5 hours to complete. The heating rates are the same for all cones. The temperature in segment 4 is 250° less than the final temperature for the cone.

**Firing times are approximate, based on a beginning temperature of 70°F/21°C firing to Cone 04.*

Segment	Rate	Temperature	Hold
1	200°/hr	250° F	0
2	400°/hr	1000° F	0
3	180°/hr	1150° F	0
4	300°/hr	1694° F	0
5	120°/hr	1946° F	0

Cone 04, Medium Speed

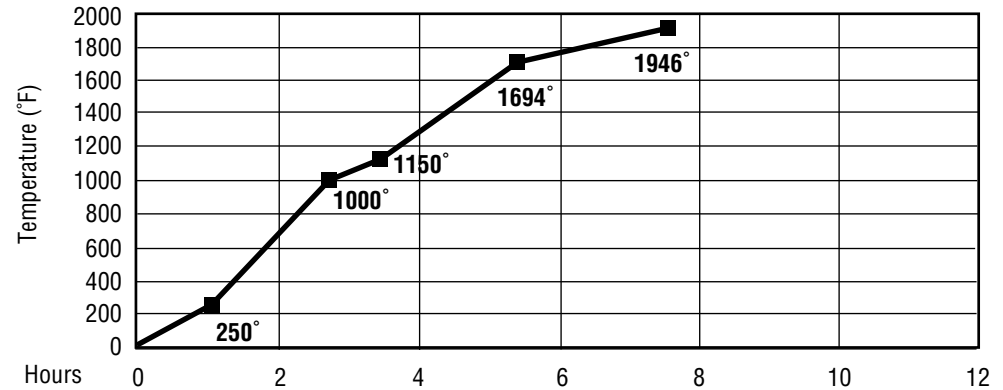



Cone Fire-Fast

Fast is a speed that will take approximately 4 hours* firing depending on the cone selected. Fast speed is probably not the best choice to use during a bisque firing as it does not allow enough time for the physical water to burn off and the structural changes to occur. If you were to program the segments for this firing, they would look like the chart at right:

The graph at right illustrates the segments of a cone 04 firing in Cone Fire mode, fast speed. The firing will take approximately 4 hours to complete.

If Review is pressed near the end of the firing (within one hour of completion) an adjusted cone temperature of 1937° for Cone 04 will be displayed. For more explanation, see Appendix 2, Cone Chart and Heat Work. This section explains why the end temperature may be higher or lower than the cone table indicated.

**Firing times are approximate, based on a beginning temperature of 70°F/21°C firing to Cone 04.*

Segment	Rate	Temperature	Hold
1	570°/hr	1704° F	0
2	200°/hr	1957° F	0

Cone 04, Fast Speed

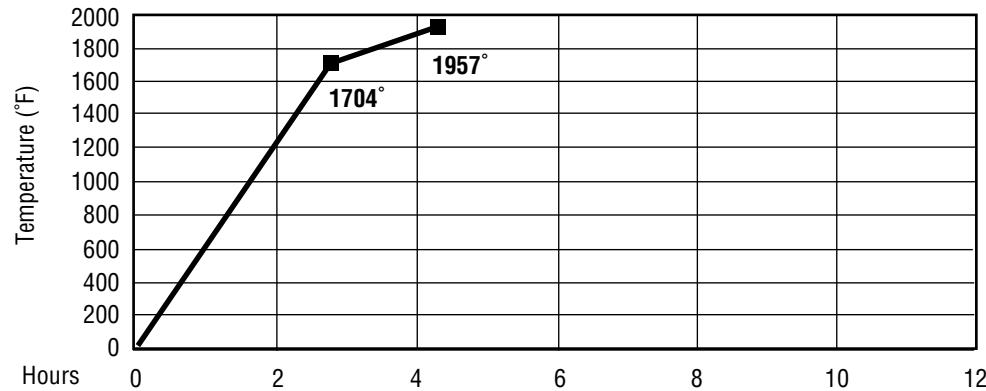

PROGRAMMING IN THE CONE FIRE MODE.

Messages and prompts in the Cone Fire Mode.

A word about the funny digital characters: they may seem unreadable now, but you'll get used to them.

PF Power Failure, may indicate that the controller was just plugged in. Press Enter to clear the PF message and display internal kiln temperature.

HOLD Hold time desired at end of firing is entered in hours and minutes up to a maximum of 99 hrs. 99 mins. To enter, numbers on the right of the decimal are minutes, to the left are hours. The default setting is 00 hrs. 00 mins.

ConE Requests firing cone number. Be sure to enter the correct number keeping in mind that cooler firing temperatures have a "0" in front of the number.

SPd Requests the speed of firing, either slow, medium or fast.

IdLE When idle is flashing alternately with the internal temperature of the kiln, the kiln is in IDLE MODE and ready to program.

(Continued overleaf)



CPLt Indicates that the firing cycle is complete. Elapsed firing time in hours and minutes is displayed.

-ON- Briefly displayed indicating that the kiln has started.

deLA Indicates the amount of time in hours and minutes to delay the start of firing. A maximum of 99 hrs. 99 mins. is allowed. Digits to the right of the decimal are minutes, to the left are hours.

ALAr Signals the operator that the kiln has reached a pre-programmed temperature. The default setting is 9999°F for no alarm.

PrHt Requests a preheating time be entered.

A SAMPLE CONE 06 FIRING, MEDIUM SPEED

At right is a sample of keystrokes for a Cone 06 firing with medium speed and no hold.

Helpful hint: If you make a mistake when entering a cone number, don't be discouraged. Simply clear the display by pressing all zeroes. Press Enter. This will take you back to ConE. The display will flash the last value that was input correctly. Enter the correct value and Press Enter. If a number was incorrectly entered for HOLD, deLA or ALAr, clear the display by entering all zeros. Enter the correct digit(s) for the step being programmed. Press Enter. If you have already pressed Enter, you must go back through the program by pressing Enter until you reach the point where the mistake was made.

Step	Press	Action	Display
1	Cone Fire	Enters Cone Fire Mode	ConE
2	0 6	Enters Cone number desired*	06
3	Enter	Stores new Cone number	SPd
4	Med	Enters speed desired	MED
5	Enter	Stores new speed	HOLD
6	5	Enters new hold time	.05
7	Enter	Stores new hold time	(Kiln Temp.)
8	Review	Reviews program segments to ensure accuracy*	(All segments)
9	<i>Set options if desired:</i>		
	Delay	Enter delay of start of firing (eg: 1/2 hr. = 00.30)	00.30
	Alarm	Enter temperature at which alarm sounds (1500)	1500°F
	Review	Reviews all programmed instructions	ConE, SPd, HOLD, deLA, ALAr (followed by their values)
10	Start	Begins firing sequence (or Delay countdown)	-ON-

Programming a PREHEATING CYCLE

You can now program a preheating or soaking cycle which will run prior to your Cone Fire program. The program will go from room temperature at a rate of 80°/hr. to 180° and hold at that temperature for the amount of time you enter up to 99 hrs 99 min.

Preheat Instructions

Press "F/C", "7", "5"

"PrHt" alternates with the currently selected option, "on" or "off".

Use the number "1" key to toggle between these two choices.

Press "ENTER" when the option you want is displayed.

If preheat is on then after pressing the cone fire button "prHt" will be displayed and you enter the time you want to hold. Press "ENTER" and proceed with cone fire programming.

**Caution: Be sure you have entered the correct Cone number. 06 is much different from 6! If you are not certain of the difference, check the Cone and temperature with the Cone Chart in Appendix 3.*



Ramp/Hold Mode

An important note

To effectively use Ramp/Hold firing programs, it is imperative to understand heat work theory. See Appendix 2 for further details.

Description

The Ramp/Hold mode allows you to create your own firing profile. The profile can consist of 1 to 8 segments. Each segment consists of three parameters: the **rate** of temperature rising or cooling in °F or °C per hour; the **temperature** to fire to during that segment in °F or °C; and **hold time** at the designated temperature for that segment. The user can program an **alarm** to sound when a given temperature is reached.

Rate

Rate can vary from 13° to 9999°F/hr. For comparison, in the Cone Fire mode Slow rate, the initial rate is 80°F/hr and in Medium the initial rate is 200°F/hr. In Ramp/Hold mode, you decide how fast you want the kiln to rise in temperature. Segment 1 will always have a heating rate.

Note: If you should program an unachievable heating rate such as 9999°F/hour, the kiln cannot heat that fast

and will turn On and stay On, effectively duplicating a High setting on a switch. The actual rate of heating will be the maximum that particular kiln can achieve on High. Generally, the maximum heating rate in a fully loaded kiln is about 100°F per hour as it approaches the top cone rating for the kiln.

Temperature

Temperature is the heat you want to reach before holding or proceeding to the next rate. The maximum temperature is 2400°F (1300°C). If a Hold temperature is less than the previous temperature entered, the controller will ensure that the kiln will not cool faster than the programmed rate. Read Appendix 3 on heat work before you use rate and temperature to emulate a cone firing.

Hold

Hold is the amount of time in hours and minutes you want to sustain at a given temperature before it continues to the next segment. Hold can be from zero to 99 hours 99 minutes. For example, a hold of 15 minutes will appear in the display as 00.15. Digits to the right of the decimal are minutes; digits to the left are hours.

Segment	Rate	Temperature	Hold
1			
2			
3			
4			
5			
6			
7			
8			

Recording your USER programs

Before you begin input, copy this page or create a chart to include all of the segments you plan to program. You may have 1 to 8 segments. Each segment may have three components as shown in the blank chart above.

Calibration for critical work

For those who are doing critical work which needs exact temperatures, periodically check the accuracy of the thermocouple by placing witness cones on the shelves. Observe the deformation of the Self-Supporting Cones at the end of the firing. If the shelf cone bends to maturity

before the kiln turns off, press **Stop** and make a note of the internal temperature.

Adjust the programmed cone or end firing temperature using the knowledge gained from the cones from the previous firing. Make a note of any adjustments you have made so that your future firings will be more accurate.

Inspect the thermocouple element regularly and replace it as described on page 7 (wall-mounted controller) or 35 (KM kilns) if it shows signs of flaking or thinning.



PROGRAMMING IN RAMP/HOLD MODE.

Messages and prompts in the Ramp/hold Mode.

Some of the characters may appear funny to you now, but soon you won't even notice.

PF Power Failure, also displays when the controller has just been just plugged in. Press Enter to clear the message and display the internal kiln temperature.

SEGS (May look like 5E65.) Asks for the number of segments in the USER profile.

rA 1-8 Rate for each segment 1-8.

°F 1-8 Temperature for each segment 1 through 8. Cone Table can be used to look up cone equivalent values while programming. Please keep in mind the Time/Temperature equation regarding heat work discussed in Appendix 2

Hld 1-8 Hold for each segment, 1-8.

USER Refers to the program you wish to run or retrieve. As many as six programs may be stored in permanent memory.

CPLt Indicates that the firing is completed for the number of segments requested. Firing time in hours and minutes is displayed.

-ON- Indicates that the kiln has started.

deLA Indicates the amount of time to delay the start of firing. Digits to the right of the decimal are minutes, to the left are hours.

ALAr Signals the operator that the kiln has reached a pre-programmed temperature. The default setting is 9999 °F for no alarm.

IdLE When IdLE is flashing alternately with the internal temperature of the kiln, the kiln is in IDLE MODE and ready to program.

Storing and retrieving programs.

USER is the first prompt you encounter when entering a Ramp/hold program. A number between 1 and 6 alternately flashes along with the USER prompt, which represents the last program which was fired.

Keep a log near the kiln that tells which USER numbers are in use and records the details of each ramp and hold segment. If you want to modify or overwrite an existing program, select that number.

If several people in your studio fire the kiln, it is always a good idea to review a stored program and check to be sure that no one has modified it since you last used it.

After you have entered all the parameters of your firing profile, you may review it by pressing Review. The program will remain in the KilnMaster memory until changed. You can either leave the USER program for later use, or begin firing by pressing Start. The examples at right give specific instructions on programming and retrieving USER programs..

Segment	Rate	Temperature	Hold
1	570°/hr	1694° F	0
2	200°/hr	1944° F	0

A Sample 2-Segment Cone 04 Firing.

This Cone 04 firing at fast speed in Cone Fire mode contains 2 segments. The keystrokes needed to duplicate this 04 firing in Ramp/hold mode are shown at right.

For comparison, this Ramp/hold program emulates the Cone Fire-Fast speed Cone 04 segments shown earlier in the manual. The difference is that you are entering each piece of data.

Use the two-segment firing chart at right as your programming reference.

Helpful hint: When programming a segment, if you make a mistake entering a number, don't be discouraged. Simply clear the display by pressing all zeros, then enter the correct digits for the step you are programming. If you have already pressed Enter, you must go back through the program by pressing Enter until you reach the point where the mistake was made.



Step	Press	Action	Display
1	Enter	Clears PF message and displays kiln temperature	<i>Kiln Temp.</i>
2	Ramp/Hold	Enters Ramp/Hold Mode	<i>USER / No.</i>
3	1	Selects USER profile number 1	<i>1</i>
4	Enter	Opens the USER profile to receive data	<i>SEGS / No.</i>
5	2	Enters number of segments in profile	<i>2</i>
6	Enter	Stores the number of segments entered	<i>rA1 / No.</i>
7	5 7 0	Enters the heating rate per hour of segment 1	<i>570</i>
8	Enter	Stores the segment 1 heating rate	<i>°F 1 / No.</i>
9	1 6 9 4	Enters the °F temperature to reach in this segment	<i>1694</i>
10	Enter	Stores the target temperature for segment 1	<i>HLd1 / No.</i>
11	0	Enters no hold time	<i>00.00</i>
12	Enter	Stores the hold time for segment 1	<i>rA2 / No.</i>
13	1 0 8	Enters the heating rate per hour of segment 2	<i>108</i>
14	Enter	Stores the segment 2 heating rate	<i>°F 2 / No.</i>
15	1 9 4 4	Enters the °F temperature to reach in this segment	<i>1944</i>
16	Enter	Stores the target temperature for segment 2	<i>HLd2 / No.</i>
17	0	Enters no hold time	<i>00.00</i>
18	Enter	Stores the hold time for segment 2	<i>HLd2 / No.</i>
19	9999	Enters temperature to sound alarm (no alarm)	<i>9999</i>
20	Enter	Stores the alarm temperature	<i>---- / Temp.</i>
			<i>The display will flash "----" twice after programming is complete. Then it will begin flashing the internal temperature.</i>
21	<i>Set options if desired:</i>		
	Delay	Enter delay of start of firing (eg. 1/2 hr. = 00.30)	<i>00.30</i>
	Alarm	Enter temperature at which alarm sounds (1500)	<i>1500°F</i>
	Review	Reviews all programmed instructions	<i>SEGS, rA1, °F 1, HLd1, rA 2, °F 2, HLd2, deLA, ALAr</i>
22	Start	Begins firing sequence (or Delay countdown)	<i>-ON- / Temp.)</i>

Quickly accessing a stored program.
If you know that a program you wish to use has not been modified since you last fired with it, you do not have to review all the programming steps.

The instructions below show the details on quickly accessing a stored program. This is especially useful for production studios which need both repeatability and productivity.

Step	Press	Action	Display
1	Ramp/Hold	Enters Ramp/Hold Mode	<i>USER / No.</i>
2	1 to 6	Selects one of your 6 USER profiles	<i>1 to 6</i>
3	Enter	Opens the USER profile to receive data	<i>SEGS / No.</i>
4	Stop	Closes and stores the USER program selected <i>Note: Stop only has an effect at this point in the program. If you start programming, you must press Enter to all prompts and go through the programming cycle.</i>	<i>----</i>
5	Review (Optional)	Reviews that all of the information is input correctly and the proper program is selected	<i>SEGS, rA1, °F 1, HLd1, rA 2, °F 2, HLd2, deLA, ALAr</i>
6	Start	Begins firing sequence (or Delay countdown)	<i>-ON- (then Kiln Temp.)</i>

The Skip Step advanced feature.
Advanced KilnMaster users asked us for the ability to skip the rest of a step in Ramp/Hold mode. This is useful if you know from experience or by viewing cones through a peep hole that the heat work is complete for that segment. You can skip the balance of that segment and go on to the next one.

To skip the balance of a segment:

1. Press **View**, then **Enter** in quick succession.
2. The display will show *SStP* (Skip Step).
3. Press **Enter** again.
4. The display will show the new segment number.

This feature is not available in Cone Fire Mode.



SAMPLE RAMP/HOLD PROGRAMS

You may find the following examples of Ramp/Hold programs helpful. If nothing else, they will serve as a guide for developing your own programs. Label your new program and keep it handy for quick reference on a 3x5 file card or a photocopy of the blank Ramp/Hold table on page 23.

Candling

This Cone 10 firing demonstrates a slow firing with holds at the lower temperatures. This profile would be gentle and safe for pottery firing of ware which had not dried sufficiently before firing. With modification to the final firing temperatures, this procedure may be used with other types of clay.

Segment	Rate	Temperature	Hold
1	50°/hr	150° F	6.00
2	150°/hr	1100° F	2.00
3	570°/hr	2100° F	0
4	108°/hr	2345° F	0

Controlled Cooling

Normal firing to cone 5, rapid* cooling to 1950° with a 30 minute hold. Slow cooled to 1100°, then normal cooling to room temperature. This is a useful profile when glaze firing to ensure gentle cooling and avoid cracking or crazing.

Segment	Rate	Temperature	Hold
1	300°/hr	1100° F	0
2	500°/hr	1915° F	0
3	108°/hr	2165° F	0
4	9999°/hr*	1950° F	.30
5	150°/hr	1100° F	0

Quick Fire

A fast fire to Cone 018, rapid* cooling to 1100° with a 30 minute hold, then normal cooling to room temperature. A simple approach to firing overglazes and china paints.

Segment	Rate	Temperature	Hold
1	9999°/hr*	1314° F	0
2	9999°/hr*	1100° F	.30

**9999 is the default for the maximum heating or cooling rate. The actual rate will vary with the kiln model, density of the load, air circulation, and the room temperature.*



Porcelain Fire

This 2 segment Porcelain firing is recommended by Seeley's to fire the porcelain they manufacture. Upon completion a Cone 5 witness cone should be touching the shelf, Cone 6 should have a 10° bend and a Cone 7 witness cone should have no bend at all.

Segment	Rate	Temperature	Hold
1	500°/hr	2000° F	0
2	100°/hr	2185° F	0

Crystalline Glaze

This example is fired to Cone 10, taking approximately 11.5 hours to fire, with a rapid drop in temperature to 2050° and a hold of 3 hours. To assist with rapid cooling from peak temperature to hold temperature, one may pull peep plugs. Replace peep plugs when hold temperature is reached.

Segment	Rate	Temperature	Hold
1	200°/hr	800° F	0
2	150°/hr	1250° F	0
3	300°/hr	2100° F	0
4	108°/hr	2330° F	0
5	9999°/hr*	2050° F	3.00

Glass Fusing

Glass firing is specialized and will require some experimentation to arrive at the perfect program for your kiln and glass products. However, this will give you a place to start experimenting.

Segment	Rate	Temperature	Hold
1	600°/hr	1480° F	.15
2	9999°/hr	1000° F	2.00
3	90°/hr*	970° F	2.00
4	120°/hr	750° F	0

**9999 is the default for the maximum heating or cooling rate. The actual rate will vary with the kiln model, density of the load, air circulation, and the room temperature.*



Key Functions of the Controller

Temperature Scale Selection.

You can select either the Fahrenheit or Centigrade temperature scale. You must select a scale before pressing Start. Do not change the scale during a firing. The scale remains in permanent memory. To change to Centigrade or back to Fahrenheit, follow these steps:

Step	Press	Action	Display
1	°F or °C	Selects Fahrenheit or Centigrade scale	CHG°
2	Enter	Stores the new selection (Decimal point in lower right corner of display indicates °C)	(Flashes Temp.)

Delay Start

Delay start allows the operator to program the kiln now for a start at a later time that is more convenient. The option provides for a delay programmed in hours and minutes up to 99 hours and 99 minutes. This option is best utilized when a Skutt EnviroVent kiln ventilation system is installed on the kiln. With an EnviroVent, the system is completely automatic. No one will have to be close by to close the lid at the appropriate time.

The delay time is held in memory from one firing to another. To clear the option without clearing the entire program, enter 0 for delay time.

Setting a Delay can begin when the internal kiln temperature is flashing.

Step	Press	Action	Display
1	Delay	Enters delay start mode	deLA
2	0 - 9999	Selects time (hrs.min) to delay start of firing	0-99.99
3	Enter	Stores delay time until reprogrammed. Screen begins flashing internal kiln temperature.	(Flashes Temp.)

Alarm

The Alarm tells you when the kiln has reached the temperature you selected. The alarm sounds until you turn it Off by pressing Enter. When the alarm sounds it does not interrupt firing. Pressing Enter to stop the alarm does not interfere with the program.

The alarm temperature can be reset during firing without disturbing the firing program. Do not press Stop during the firing to reprogram the alarm.

When not in use, the alarm should have a value of 9999 entered so it will not sound.

One example of alarm use would be to set it for 1000°F/538°C to alert you that it is time to lower the lid. The following steps describe how to set the alarm temperature.

Step	Press	Action	Display
1	Alarm	Enters alarm mode	ALAr
2	0 - 9999	Selects temperature at which alarm is to sound	0-9999
3	Enter	Stores the new alarm temperature. Screen begins flashing internal kiln temperature.	(Flashes Temp.)

A sample heating alarm is illustrated below using a two segment Ramp/Hold program. The Alarm is programmed after the Ramp/Hold.

Segment	Rate	Temperature	Hold
1	570°/hr	1566° F	0
2	108°/hr	1816° F	0

The Alarm is set for 1500°F. The alarm will sound at 1500° while the kiln is heating to 1816°. When the alarm sounds, press **Enter** to stop it. The kiln will continue to fire the program until it is complete.



Review

The Review mode can be entered from the “flashing internal kiln temperature”. **Caution:** Pressing Review during firing momentarily stops operation of the kiln, allowing temperature to drop. This drop in temperature will increase firing time and may also cause a slight overfire if this procedure is repeated frequently during firing.

After displaying the current program, the screen will return to its prior state. The adjusted temperature is displayed during the last hour of Cone Fire Mode. See Appendix 2 for more information on heat work.

The values shown during Review are as entered in the original profile. This is a good time to recheck the temperature value of the cone you entered during Cone Fire mode. If the kiln has been started with a 3 hour delay time set and one hour later you enter Review mode, the delay value will still be displayed as 3, not the remaining 2 hours. When Review mode is finished for this example, the display will be showing a time value indicating the time remaining in the delay start segment of the firing profile. The Review display is quite rapid, so you may need to go through several sequences to see all the segments. The following are the steps to review the program:

Step	Press	Action	Display
1	Review	Displays all programmed functions and values	(See below)

Review Display for Cone Fire Mode

<i>ConE</i>	Cone value
<i>SPd</i>	Firing speed: Slow, Med, Fast
<i>HOId</i>	Time in hrs. min. to hold
<i>deLA</i>	Delay start in hours
<i>ALAr</i>	Temp. when alarm will sound

Review Display for Ramp/Hold Mode

<i>USER</i>	Stored program number
<i>SEGS</i>	Number of segments
<i>rA 1-8</i>	Rate of temp change ea. segment
<i>°F 1-8</i>	Temp. to reach each segment*
<i>HLd 1-8</i>	Hrs. min hold each segment
<i>deLA</i>	Hrs. min delay before firing
<i>ALAr</i>	Temp. when alarm will sound

*If Centigrade scale is elected, display will show °C.

Cone Table Feature

This function allows you to look up the final temperature the controller will reach for a given cone value. The built-in cone table uses a heating rate for self-supporting cones of 108°F/hour. It is vitally important that you know the temperature you intend to reach and the temperature tolerance of the clay you are working with. If the wrong cone number is entered, a possible overfire may occur. Cooler cones begin with a 0 in front of the number. The larger the number with a 0 in front, the cooler the firing temperature. High fire cones begin at 1 and go up. The larger the number, the hotter the firing. See the Cone table in Appendix 2.

This function can be entered when the internal temperature of the kiln is flashing or when Ramp/Hold mode is asking for temperature in degrees for any of the six segments. The steps are as follows:

Step	Press	Action	Display
1	Cone Table	Enters cone table mode	<i>ConE</i>
2	0 2 2 - 1 0	Selects desired Cone (eg: 06)	<i>06</i>
3	Enter	Sends temperature to Ramp/Hold program.	<i>1819</i>

View

The View function is used during Ramp/Hold firing to display the current segment of program currently in operation. If this function key is engaged during a Cone Fire, the data displayed will not resemble your programmed input. Unlike Review, only the current segment will be displayed.

Step	Press	Action	Display
1	View	During Ramp, displays heating rate and segment. During Hold, displays Hold and segment.	<i>rA, 1-8</i> <i>HLd, 1-8</i>



Powering the Kiln

When the kiln is plugged in, the display reads PF. Press Enter and wait for the internal temperature to flash before proceeding. The internal temperature will flash constantly even when the kiln is not in use. The controller is not activated until Enter is pressed and a choice of Cone Fire Mode or Ramp/Hold Mode is selected.

At the end of a firing, the display will read CPLt until you press Enter, at which time it will flash only the internal kiln temperature. In areas where there are frequent power fluctuations or electrical storms, it is wise to unplug the kiln, or turn its breaker off, when it is not operating.

Stop Firing

Pressing the Stop key will turn the controller's output off and cause the display to flash the internal temperature of the kiln. You can stop any time during operation. During a firing operation, the only function of Stop is to terminate a program. As explained on page 25, it is can also be used to quickly enter a stored USEr profile during programming.

Start Firing

From the flashing temperature, press Start to begin a firing. The controller will display On while it does a self-check. The amount of time in a delay start is then displayed and is counted down until zero delay is remaining, at which time the firing starts. During firing, the kiln temperature is displayed.



Questions and Troubleshooting

How can I correct a value that's been incorrectly typed before pressing Enter?

Clear the display by pressing all zeros, then enter the correct digits for the step you are programming. A cone number incorrectly entered is not corrected this way. After pressing **0000** and **Enter**, the screen will again ask for a cone number. Enter the correct cone number and continue entering other data. Press **Cone Fire**. Enter the correct cone value and press **Enter** for all other questions. Press **Start** when you are satisfied that all values are correct. See pages 19-22 for detailed instructions.

How can I change only one value for a complicated Ramp/Hold firing profile without reentering the whole program?

Use the method for entering a new program, but press **Enter** for every value that will remain the same. Make a change in the value that is incorrect, then continue. See pages 23-25 for detailed instructions.

How can I change the firing profile during the firing process?

Press the **Stop** key. This will stop the firing. Use either the Cone Fire mode or Ramp/Hold mode to input the new firing profile for the remaining portion of the firing. Press **Start** to resume the firing. The

controller will automatically determine where to enter the program (based on the current internal temperature) to proceed with the firing. See pages 19-22 for detailed instructions.

How can I fire my kiln with preprogrammed instructions for a certain cone number?

Set the kiln in Cone Fire mode where the only entries are cone number, firing speed and hold time.

How will I know what the temperature of a given Cone will fire to?

Proper heat work is a factor of both time and temperature. Using visual cones is the most accurate way to ensure proper firing. The built-in Cone Table gives firing temperatures based on optimum firing conditions. According to Orton's information, a Cone 04 with a heating rate of 80° F will produce a final temperature of 1935° F when fired in Slow Mode. A heating rate of 200° F will produce a final temperature of 1954° F firing in Fast Mode. As mentioned earlier, firing at a slower rate usually results in ware with fewer problems.

KILN PROBLEMS

The kiln shuts off too early.

The kiln can be restarted if the cones on the shelf indicate an under-fired load. (This should be used only if you were present when the kiln fired off.) The cones are no longer accurate if they have cooled

much from the time of shut off. To restart follow these steps.

1. Press **Cone Fire** or **Ramp/Hold** to view the firing just completed.
2. Press **Enter** to accept any of the segments that are correct until the point where the cone number or final firing temperature is requested.
3. Program in a hotter cone or higher firing temperature. You could also add a few minutes of hold time at the final firing temperature.
4. Press **Start** after the reprogramming is complete. The kiln will begin firing based on current temperature and will fire to completion using the newly programmed data.

Helpful hint: If the firing is just slightly underfired, program 5 minutes of hold time at the final firing temperature. This will allow the sections of the kiln that are somewhat cooler to catch up to the hotter sections.

The kiln says CPLt but the kiln won't cool off.

Check to see if elements are still glowing inside the kiln. This may indicate that a relay has stuck and needs to be replaced. Unplug the kiln and contact your distributor for further information.

At night I see a blue flash coming out of the control box when it clicks. Is it serious?

The flash occurs when the contacts open causing a small arc. This is a normal occurrence and should not be a concern.

I pressed a cone number but the new cone number is not displayed.

After entering new values for any step in programming, it is necessary to press **Enter**.

I programmed a Ramp/Hold profile and when I pressed Start, the alarm sounded.

Review the program to insure that all segments of the profile have a value entered. Also, check the alarm to see if a value has been entered that is lower than the room temperature. The default setting for the alarm is 9999.

The kiln is plugged in, but there is nothing on the display.

First check your circuit breaker to ensure it has not tripped. If the circuit breaker is okay, check the fuse. The fuse is located on the bottom of the KM-1 Controller and on the lower left side of the kiln mounted controller. Turn the knob a quarter turn counter-clockwise to remove the fuse. Check the fuse wire, and if broken, replace the fuse. If the fuse is smokey, replace it. After the fuse is replaced, if the new fuse blows, check for other possible causes. A blown fuse may be caused by a short in the circuit or a power surge.

(More overleaf.)



Some segments of the display are dimmer than others.

When a few segments of the LED display become dimmer than the others, the problem may be the result of age, indicating the circuit board may soon fail. Another possible cause is exposure of the controller to high heat. This situation needs attention. Do not use the kiln when this problem is present. Contact your distributor.

The thermocouple is flaking.

Flaking is normal with Type K thermocouples, especially when high fired. Use a soft bristle toothbrush to remove the flakes and vacuum them from the kiln so they do not attach to your ware. Remove the thermocouple element periodically and check it for thinning.

The end firing temperature is different now than when I first got my kiln and the results do not seem quite right. What should I do?

After about 50 Cone 6 firings, or 150 Cone 04 firings, it is necessary to replace the thermocouple element. When the temperature seems to drift, it is an indication that the thermocouple is becoming thinner and wearing out. Another possibility is a cone correlation difference. Fine tuning of firing temperatures is available. Call the Skutt factory for instructions.

WARE IMPERFECTIONS

Common glaze faults

Crawled glaze. In "crawling", blank or bald spots appear in the glaze surface after firing. Crawling may be caused by having a dusty or dirty bisque surface, or applying the glaze heavily. Skin oils from excessive handling of greenware may clog clay pores, causing the glaze to be repelled. Hard spots in the clay surface created by excessive sponging or polishing of the greenware is also a cause. To salvage such a piece, apply additional glaze to the bare spot and refire, or cover the entire piece with a textured glaze and refire.



Cratered or bubbled glaze. In this glaze error, the craters develop as a result of body gases erupting through the glaze and "freezing" as the kiln cools. This condition is caused by underfiring. To salvage such a piece, grind down the high spots, apply a thin coating of glaze and refire to a higher temperature.

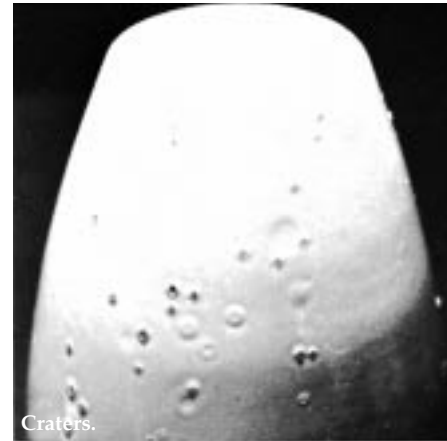

Pinholes. Pinholes are tiny indentations in the glaze surface which are generally no larger than the point of a pin. This fault may occur in almost any type of glaze, and is caused by underfiring. To salvage a piece, refire at a higher temperature.

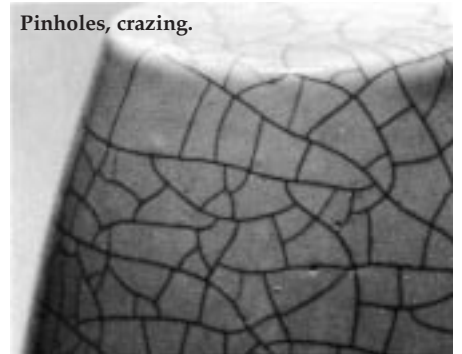

Sagging glaze on a vertical surface. Sagging or running glaze is generally caused by too heavy an application of glaze. It is a warning sign that too much glaze is being applied. Take extra care with similar pieces.

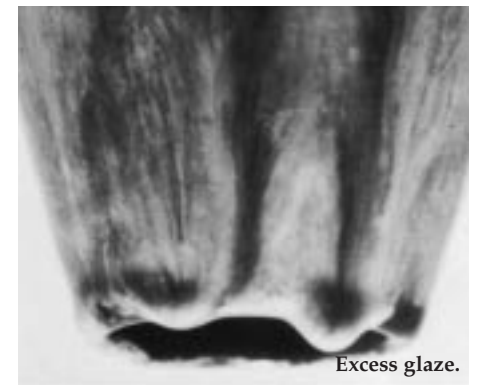



Excessive application of glaze. The example shown demonstrates the type of surface which can result from too heavy an application of glaze. This error is difficult to salvage, so remember to apply less glaze in the future. In general glaze should be the thickness of a postcard when applied. Allowing the glaze to dry thoroughly between coats will assist in identifying the amount of glaze that has been applied.

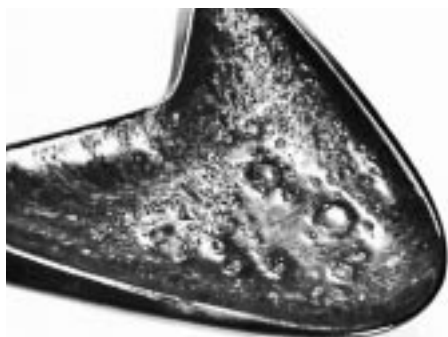

Excess glaze.

Discolored overglazes. Underfiring occasionally leaves small pin holes or pores in the glaze that can't be seen without a magnifying glass. If there is poor ventilation in the kiln, china paint oils may seep into these pores and burn to charcoal, seriously affecting the color of the finished piece.

You can sometimes repair the damage by soaking the piece for several hours at a low red heat about 1200 °F/650°C, cooling and inspecting to be certain that all the carbon has been oxidized, and then giving the piece a true glaze firing.

Cracks in the body. When a crack occurs in the body, examine the glaze at the edge of the crack. If the glaze is inside the crack or rounded over the corners, the break occurred early in the glaze firing, and was probably present in the clay body before the piece was glaze fired. In some instances a sound appearing piece of ware will crack during a glaze or overglaze firing. This can be caused by an excess of water used in the original clean-up of the greenware. Too much moisture applied to an area of greenware causes that area to expand while the dry or slightly damp areas have already gone through normal shrinkage. Even if a piece of dry, cleaned greenware shows no visible cracks, it is possible an internal stress is there. This crack can open up during later firings. If the glaze at the edge of the crack is sharp, the break developed after the glaze was fired. This type of crack is usually due to opening the kiln door or peepholes while the ware is still hot.

Crazing. Crazing is characterized by a network of fine cracks in the glaze surface. It may be caused by underfiring bisque, clay or glaze, incompatible clay and glaze, or by opening the kiln door before the ware is completely cooled. Crazing might be eliminated by refiring the piece to a temperature one cone higher than the original firing.



Delayed or aftercrazing. Crazing may also occur days or months after the piece has been fired. Although the finish may look perfect when it is first removed from the kiln, crazing may occur. While underfiring may not be the direct cause of immediate crazing, it is the major cause of delayed crazing. To correct it, refire the piece to the cone recommended by the manufacturer of the glaze. Allow the kiln to cool naturally.

Shiny matte surface. A matte glaze which becomes glossy in the glaze firing is generally caused by overfiring. It is extremely difficult to correct. Remember to fire to a lower temperature in the future.

Textured glazes, smoothed. A textured glaze is formulated to develop an irregular surface when fired. If it fails to do so, it is generally due to too light an application of glaze. It is extremely difficult to correct this condition. Reglazing and refiring rarely will help.

Cloudy or discolored glazes. This condition is characterized by a muddy or discolored appearance in the fired glaze. It may be caused by using dirty or contaminated brushes, by not leaving enough space between the glazed pieces during firing so chemical fumes jump from one glaze to another, or by placing the piece too close to the kiln elements. It is extremely difficult to correct.

Grainy glaze. Uneven or irregular color in the glaze surface is generally caused by too thin an application of glaze. To correct, apply a coat of glaze, then refire.

Gray or discolored red glazes. Gray wash out, or black areas in the red glaze may be caused by too thin an application of glaze, the red glaze being fired with colors which it is incompatible, (generally yellows and greens) or firing too hot. This may also be the result of too little oxygen present during the firing. Cone 07 to 06 is usually the best range for red glazes. To salvage, apply a heavy coat of glaze and refire. Use of the Skutt EnviroVent is another way to eliminate these problems.

Underglaze peeling. Underglaze may pull away from the clay body. This may be caused by too heavy an application, or not firing the underglaze before applying glaze. It is extremely difficult to correct this error.

This section on glaze faults prepared in collaboration with Martin L. LaVor who assisted with information and illustrations.



Repairs

KILN REPAIRS

Happily, your Skutt kiln will give you few occasions to refer to this section. The careful repair person can keep a Skutt kiln operating with no difficulty. But if you are not mechanically inclined, it is best to call an authorized Skutt service person, or competent small appliance repair person or electrician. Take this owner's manual along with you. To transport your kiln, handle sections by their outer edges, and place them on a flat surface, cushioned by folded blankets.

Wall repairs.

The premium brick used in Skutt walls will withstand thousands of firings without crumbling. Broken element grooves are usually the result of carelessness in handling the kiln sections or in loading shelves.

It's almost impossible to cement a broken groove lip back into place without contaminating the heating element. If the element starts to sag out of position, hang it on 1 1/2" element pins inclined toward the back of the groove.

Caution: Elements become very brittle after a few firings, so if straightening is necessary, heat the element electrically to visible redness, unplug the kiln from the wall and immediately push the element

back into position with a metal implement, reheating whenever stiffening is detected. Place your hanging pins in a straight row and the element will serve the rest of its normal life.

Replacement of wall bricks is simple in Skutt kilns.

1. Order needed bricks from the parts list available from your Skutt dealer. Replacement of terminal bricks involves cutting and renewing element connectors and should normally be postponed until it's necessary to replace that element.
2. If repairing a top ring, disconnect the lid and remove all fittings from the jacket.
3. Remove the screws that hold the control panel to the kiln. Swing the panel open. Slide the connectors off the terminal strip (they are pre-numbered for easy identification). Unplug the thermocouple tabs which are marked positive and negative. Lift the box straight up to remove it. Place on a clean flat surface.
4. Place the ring, damaged side up, on a perfectly flat surface such as the kiln lid.
5. Pull out the straight element pins at the ends of the damaged brick.
6. Gently lift elements from troughs with a pick or long-nose pliers and gently lift them out into firing chamber just far enough to allow damaged brick to be slipped out. Remember that the elements are brittle.

7. Loosen the worm-type jacket fasteners equally, 1/2" to 3/4".
8. Make sure element troughs in the brick are proper side up. Insert the new brick. This is easiest if a helper holds the adjoining bricks away.
9. Hold the worm-type jacket fastener housings with pliers and tighten them evenly until they meet resistance. Slip elements into new grooves and pin down.
10. Use sandpaper over a wood block to sand the edges of new brick down flush with its neighbors. Vacuum thoroughly when sanding is completed.
11. Replace hinges and hardware, and position the kiln so you can finish tightening the jacket just before the kiln shuts off on your next Cone 06 or hotter firing.

Floor repairs.

Glaze drips on a properly kiln washed floor can easily be removed without damage to the surface below. Remember to remove all glaze drips before taking the kiln to porcelain/stoneware temperatures, where the glaze will over-fire and soak through the kiln wash.

The floor can be patched level again even if several square inches have been damaged to a depth of 5/8". Using a sharp knife or X-Acto tool, simply undercut or dovetail the edges of the area to retain a patch made by mixing dry high

fire kiln wash with just enough water to form a very stiff putty. Compress the putty into place, and scrape flush with the rest of the floor. Allow to dry well before firing.

Don't forget that your kiln floor has two lives. Just turn it over to use the second side. The underside isn't pretty but it can be lightly sanded to remove any discoloration, kiln washed and put back into use to save you money.

Lid repairs.

Because your Skutt lid is so strongly cemented and well reinforced by its stainless steel band, you'll have to work hard to get it to develop a crack which will sift particles on your ware. Use only the contoured venting prop to "post" your lid to save the dustproof coating.

If a tall glazed piece expands enough to fuse to the lid, do not attempt to fill the resulting hole, but simply smooth its interior with sandpaper and blow clean. A coating of refractory cement will prevent the brick from crumbling and falling on your ware. Your lid has a flip side if ever needed. Just remove the screws holding the hinge leaves, turn the lid over, and reattach the leaves to new 3/32" holes drilled in the lid's band.



Replacing elements.

While Skutt kiln elements are not difficult to replace, they require electrical connector tools. We recommend you ask your Skutt dealer about the procedure.

Replacing the thermocouple element on KM Automatic Kilns.

(See page 5 for instructions on the Wall mounted KilnMaster.)

1. Remove the screws that secure the red control box to the kiln.
2. Swing the box open.
3. The thermocouple has a yellow, insulated lead wire attached to the terminal strip with slide on connectors and marked with positive (+) and negative (-). Note: The negative (-) wire is red, not black!. Slide the connectors off the terminal strip.
4. Remove the two screws that hold the thermocouple terminal block onto the heat shield.
5. Gently pull the thermocouple assembly out of the brick.
6. Loosen the two screws which hold the thermocouple element in place as shown in the picture at right and remove it from the thermocouple block.
7. Insert the new thermocouple element in place and tighten the screws. A porcelain sleeve is included with the thermocouple element. On early KM kilns, it may be necessary to insert the sleeve into the brick to accommodate the new size thermocouple.

8. Reattach the terminal block onto the heat shield with the two screws.
9. Reconnect the thermocouple lead wire to the terminal strip, matching the positive and negative markings.
10. Close the box.
11. Replace the screws.



KILNMASTER CONTROLLER CIRCUITRY.

The KilnMaster controller components are solid state and cannot be repaired in the field. If repairs are necessary, call the factory to make arrangements for return of parts. When the switchbox is received we will evaluate the problem and call you with a cost estimate.

Glossary

Below is a glossary of some useful ceramic terms.

Aftercrazing. Glaze crazing after firing—days, weeks or months later.

Bisque. Ware which has passed through its first firing without benefit of glaze.

Candling. The practice of slow firing and holding the kiln temperature around 150° for a period of time to thoroughly dry ware.

Ceramic. In general, any man-made solid product resulting from the fusion of mineral substances. Also used to identify a type of high-talc body which fuses at moderate temperatures—Cone 05-03.

Clean-up. The process of cleaning, scraping, sanding and sponging greenware to make it ready for firing and decoration.

Cone plaque. A stand or rest for holding shelf cones during firing.

Controller. Electronic device that can be programmed for specific firing results. Can be an independent device that is wall-mounted, or built into the kiln.

Crackle glaze. A type of glaze which when fired is intentionally “crazed”. Stains or other colorants are often rubbed into the cracks to heighten the effect.

Crazing. Small hairline cracks in glazed surfaces that appear after firing. Usually caused by underfiring the body.

Dipping. Application of glaze to bisque or greenware by simply immersing it in a container of the glaze.

Dry footing. Leaving the base of a piece of ware free of glaze, or removing applied glaze from the underside of the foot by wiping. Avoids the need to stilt.

Element. A coil of resistance wire through which current passes, creating the necessary heat for firing.

Element groove. The recess in the kiln brick into which the element is placed.

Firing. The act of maturing clays and glazes by the application of heat.

Firebrick. The insulating blocks which form the chamber of your kiln.

Foot. The supporting rim at the base of a piece of ware.

Glaze. A special finely ground glass suspended in water with the aid of gum or emulsifiers. Glaze may be clear or colored; glossy, eggshell or matte; applied to bisque or greenware by brushing, spraying, pouring or dipping.

Greenware. Unfired, fragile clay forms, wet or dried.

Impurities. Minute quantities of foreign matter in clays which often cause spots in glaze.

Incising. Cutting through moist greenware in a desired pattern.



Kiln-Sitter. A Dawson trade name for their device which uses pyrometric cones to automatically and accurately shut off the kiln.

Kiln wash. A high heat-fusing powder to which you add water and brush onto kiln shelves and kiln floor. It allows removal of accidental glaze drips.

Limit timer. A device which operates by time alone, back-stopping the KilnSitter in case it is defeated.

Lusters. Iridescent overglazes, applied thinly.

Mature. A completely fired piece of ware or glaze.

Multitester. A combination ohm/volt meter.

Nesting. Placing one piece of greenware within another for bisque firing.

Ohm meter. An instrument for measuring resistance in elements.

One-fire. The practice of applying glaze to greenware and firing one time.

Overglaze. Decorative liquids applied over the glazed surface, such as china paints, lusters, gold and other metallics. Fired at lower temperatures.

Peephole. An opening in the kiln wall which allows visual inspection of the chamber during firing.

Peephole plug. A piece of refractory used to plug the peephole.

Pinholes. Small holes in the glazed surface of ware.

Porcelain. A clay body which when fired to approximately Cone 6 becomes vitreous and translucent.

Posts. Ceramic shapes that support kiln shelves during firing. Three posts per shelf are recommended.

Pouring. The act of filling a mold with slip.

Pyrometer. A high temperature thermocouple device. Most useful in glass firing.

Pyrometric cone. Slender, unfired clay pyramids which soften and bend when the kiln load has matured to the desired degree. Two sizes are available. Junior Cones are for use in the KilnSitter and Self-Supporting Cones are for visual use on shelves.

Refractory. Any high temperature clay material.

Sgraffito. The decorative technique of removing some areas of underglaze from ware with a sgraffito tool, thus allowing the color of the body to show through.

Shelf. A slab on which ware is placed in the kiln. Allows utilization of the full kiln height separated by posts.

Slip. Liquid clay slurry which is poured into molds.

Soaking. Holding a kiln at a given temperature.

Stilts. Various single and multi-pointed supports used to hold ware up off the shelves during the glaze fire, thus preventing adhesion.

Stoneware. A high fired ceramic body which is vitreous, not translucent, and usually made of native clays.

Talc. A white powder used in ceramic clay bodies.

Terminal brick. The kiln brick through which the twisted element ends pass into the switch box.

Terra cotta. A natural, low firing red clay.

Thermocouple. A pair of wires which are inserted into the firing chamber to serve as the temperature-sensing element of the pyrometer or controller.

Underglaze. Liquid coloring which is applied directly to bisque or greenware.

Venting. The practice of propping up the kiln lid (posting) to allow the escape of vapors during initial stages of firing.

Vitreous. Fully fused, waterproof ware which need not be glazed to hold water. For sanitation reasons food surfaces need to be glazed.

Volt meter. An instrument for measuring voltage at the kiln.

Warping. The loss of ware shape during firing, usually caused by overfiring or improper placement in the kiln.

Ware. Any shaped piece of pottery, stoneware, earthenware or porcelain, in any state of completion.



APPENDIX 1

KilnMaster Controller Specifications and Capabilities

The kiln-mounted controller on Skutt KM-series automatic kilns and Wall-mount KilnMaster controller have the same specifications.

Thermocouple: Type K

Electronic cold junction compensation

Power supply: 24 volt center tap transformer

Output: Drives up to 450 mA at 12 volts

Fuse: 1/2 Amp, 250 Volt

Control Panel: Sealed Touch Pad, washable

Control capabilities:

Delay Firing Start: up to 99 hours and 99 minutes

Cone Fire Mode: Entry by cone number, 3 firing speeds, Cone 022 to Cone 10.

Ramp/Hold Mode: Entry by temperature, create programs from 1 to 8 segments. Each segment can specify a rate of heating or cooling to a specified temperature with an optional hold, to maximum temperature of 2,400° F. Stores up to six complete programs.

Electronic Cone Table: Converts cone numbers to temperature.

Program Review: Review program and current segment during firing.

Temperature Alarm: Adjustable to desired temperature.

Safety features: Power Failure Detection, Thermocouple Failure Detection, Microprocessor Fault Detection.

Designed and manufactured in the USA.

APPENDIX 2

Cone Chart and Heat Work

Cone deformation

Each cone has a number which corresponds to a heating rate/temperature combination producing a cone deformation. At the beginning of the firing the cone is standing at an 8° angle. A perfectly fired cone will be bent to a 90° angle. More than a 90° angle is overfired, less than 90° is underfired.

How a cone works.

- The maturing temperature or bending point of a cone is determined by different chemical compounds which are formulated to relate to heat work in clays and glazes.
- Time and temperature are key factors in the way a cone operates. Here are some points to consider:

1. Firing clay takes varying amounts of time to be “done”. Thick walled pieces take more time to cure to the center than thin walled-cast pieces, just like a 20 lbs turkey takes longer to cook than a 10 lbs one.
2. Cones continue to drop after the firing is complete. A cone held at a temperature for a long time will continue to bend even if the programmed temperature is lower than the cone number. For example, if the end firing temperature is slightly short of maturity and put on hold for a long time, the cone will eventually bend to full maturity.
3. Cone deformation depends on heating rate and the final temperature. The chart on the next page helps define this principle. It illustrates the different temperatures a cone will bend depending on the heating rate per hour. For example, heating at 18°/hr, the cone will deform at 1890°; heating at 108°/hr, the cone will deform at 1944°, at 175°/hr, the cone will deform at 1954°.



Cone 04, 90° drop, Relationship of heating rate and shut-off temperature.

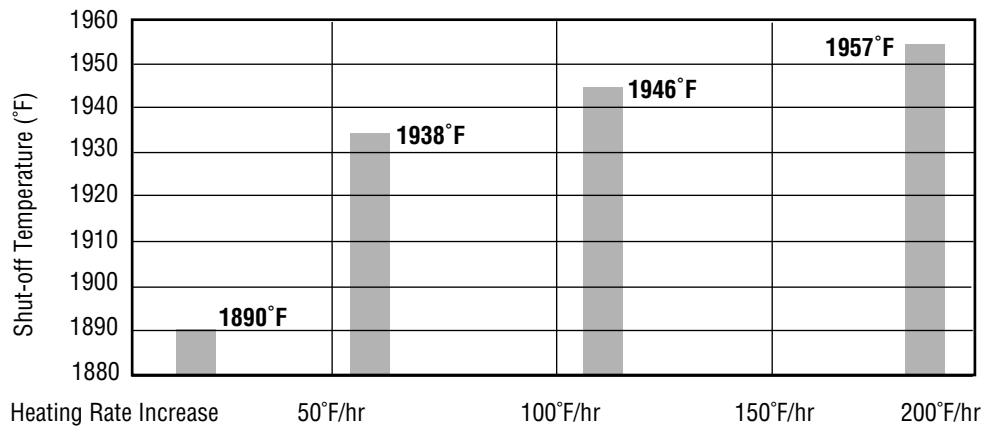

How the KilnMaster can emulate cones.

As you have just seen, a cone drops according to a complex set of factors. The KilnMaster has been designed to take these factors into account when it shuts off the kiln. Most important to the KilnMaster is the heating rate if a cone correlation is to be accurate. Here's how the KilnMaster does it.

Cone Fire mode

- By selecting Slow, Medium or Fast, the controller goes into a set routine for finishing the firing to insure a good cone correlation.
- The controller has a preset final heating rate that allows the KilnMaster to adjust the final temperature value up or down from the 108°/hour standard heating rate that is used on Orton's Cone chart.
- If the kiln cannot produce the rate, the KilnMaster still measures the actual rate and adjusts the final temperature accordingly.

Orton Pyrometric Cones

Self-Supporting Regular

Cone Number	Final Temperature at 108° F/hr
10	2345° F
9	2300
8	2280
7	2262
6	2232
5	2167
4	2124
3	2106
2	2088
1	2079
01	2046
02	2016
03	1987
04	1945
05	1888
05 1/2	1859
06	1828
07	1789
08	1728
09	1688
010	1657
011	1607
012	1582
013	1539
014	1485
015	1456
016	1422
017	1360
018	1319
019	1252
020	1159
021	1112
022	1087

Final temperature for cone maturity depends on rate of temperature increase during final 300 to 400° of firing. Courtesy Edward Orton Jr. Ceramic Foundation.

Ramp/Hold mode

In Cone Fire mode, the KilnMaster does all the calculating and thinking that goes into emulating a cone. In Ramp/Hold, you the operator must participate to get accurate cone firing results.

- If you are trying to fire to a cone temperature in this mode, you must use a rate/temperature combination in the last hour of firing that the kiln can reasonably accomplish and that is predictable. Yes, you can program 200° or 300°/hr, but a heating rate of 108°/hour is about the maximum final heating rate you can achieve with an electric kiln when high firing.
- If you program a target heating rate that the kiln can't achieve, overfiring will probably result. That final Ramp/Hold segment will run until the desired temperature is reached. However, the slower actual rate will cause more heat work to be done than you desired.
- We recommend using Cone Fire mode to emulate a cone because the controller will automatically compensate for the firing rate of your kiln. When you need to achieve a temperature between cones, we recommend making the last hour of the firing your final segment and using a rate less than 108°/hour. Use the 108°F data from the Orton Cone Chart shown here instead of any other charts you may be using.



APPENDIX 3

Controller Display Messages

ALAr

A temperature between 0° and 9999° that can be programmed to alert the operator to take action.

CHG°

Changing from Fahrenheit to Centigrade or the reverse. When operating in Centigrade a decimal will appear in the lower right corner of the display screen.

ConE

The kiln is in Cone Fire mode and needs the operator to input an appropriate Cone value from 022 to 10.

CPLt

The controller has completed a firing profile. The firing time in hours and minutes is displayed. The user needs to press **Enter**. The controller will display the current internal temperature of the kiln.

deLA

Indicates time in hours and minutes before start of firing.

Err

A software error has occurred. Press any key to display the elapsed firing time and the temperature when the error occurred. Refer to the table of Errors in Appendix 4.

F1, F2, F3, F4, F5, F6, F7 or F8

The controller is in Ramp/Hold mode. The user needs to enter an end temperature in °F or °C for **each** segment of the firing profile.

FAIL

The thermocouple and controller are not properly connected. Fix the connection, then press **Enter** to display the kiln's current temperature. Press **Start** after the connection is fixed. The thermocouple could be damaged. Check the connections, if still no luck you may need a new thermocouple.

HOLD

Indicates a holding time in hours and minutes at the end of a Cone Fire program.

HLd1, HLd2, HLd3, HLd4, HLd5, HLd6, HLd7 or HLd8

The controller is in Ramp/Hold programming mode. The user needs to enter a period of time in hours and minutes that the controller should maintain for **each** segment of the firing profile.

IdLE

Indicates controller is in IDLE MODE and is ready for programming.

-ON-

Briefly displayed at the beginning of firing to indicate that the kiln has started.

PF

Displays at the time the kiln is initially powered up. Press **Enter** to clear the

message and internal kiln temperature will flash. PF also signals when the controller has experienced a power failure of more than 2 minutes.

PrHt

The controller is in Cone Fire Programming Mode and is asking for a Preheat soak time to be entered in hours and minutes.

rA1, rA2, rA3, rA4, rA5, rA6, rA7 or rA8

The controller is in Ramp/Hold programming mode. The user needs to input an appropriate temperature in °F/hr or °C/hr for **each** segment in the profile.

SEGS

(Looks like SE65) The controller is in Ramp/Hold mode. The user needs to enter the number of segments in the profile being programmed.

SPd

The controller is in Cone Fire mode. The user needs to enter the appropriate speed; slow, medium or fast for this firing.

STOP

Designates the intentional termination of a program while in operation.

USEr

A prompt at the beginning of a Ramp/Hold program which allows the user to choose a stored program.

SStP

Short for Skip Step. Can be selected during a Ramp/Hold program when

one feels that adequate heat work has been done in the current segment. Immediately advances the program to the next segment.

flashing temperature

The kiln is off and the display is showing the kiln's current temperature.

alternating display of time and temperature

The kiln is in a Ramp/Hold firing profile and is in the soak stage. The display is indicating the kiln's internal temperature and the remaining Hold time for that segment.

decreasing time

The kiln is in a Delay start segment of a Cone Fire or Ramp/Hold mode. The display is showing the remaining time before the kiln starts to heat.

steady temperature

the kiln is in the ramping stage of either a Cone Fire or Ramp/Hold fire profile. The display is showing the kiln's current internal temperature.

decimal point between 10's and 100's
Hours.minutes being displayed.

right hand decimal point on

Kiln is operating in °C mode. To change back to °F, press **Temperature** selector then **Enter**.



APPENDIX 4

Error Messages

The following errors may appear in the window of your controller. Along with the error number, the display indicates elapsed time in hours and minutes and also the temperature the kiln reached when the error occurred. Please call your distributor or Skutt Ceramic Products at (503) 774-6000.

In addition to the error messages in the chart at right, all of which indicate a problem which needs to be corrected, there is an informational error message: **ErrP**.

When it flashes, a brief, non-critical power outage has occurred. The controller was able to resume firing and the load of ware is not in danger. It continues to alternately display with the internal temperature until you press Enter.

Error and description	Possible cause	Correction
1 Ramping up and rate is less than 12° per hour. Rise is checked every 7.5 minutes. Rate must persist for 22.5 minutes before display.	Kiln-sitter has tripped. Limit timer has expired. Elements are weak. Load is heavy. Relay failed. Low voltage.	Place one cone hotter in Kiln-Sitter. Add time to limit timer. Check elements. Reduce size of load. Check relays. Check voltage.
2 Program in hold, temperature 50° or more above hold temperature. Error must persist for more than 18 seconds before error is triggered.	Excessive heating rate going into the hold. One or more relays are stuck in the closed position.	Reprogram lower heating rate. Turn Off and unplug. Check resistance at plug with ohmmeter.
3 Program in hold, temperature 50° or more below hold temperature. Error must persist for more than 18 seconds before error is triggered.	Kiln cannot maintain temperature to reach hold. Lid opened during firing. Elements may be weak.	Do not open lid during firing. Check elements with ohmmeter.
4 Program ramping down and temperature more than 50° above last hold temperature. Error must persist for more than 18 seconds before error is triggered.	Relays may be stuck closed (failed closed).	Turn Off and unplug. Check circuit at plug with ohmmeter.
5 Program ramping down and temperature more than 50° below local set point. Must persist for 18 seconds to trigger.	Normally kiln will have plenty of power to maintain a cooling rate. Was lid opened? Elements failing?	Do not open lid until the kiln has reached at least 500° F. Check elements.
6 Negative reading detected at thermocouple, indicating it is wired improperly.	Thermocouple wires have been switched. Somewhere lead wires have been crossed.	Check and fix any backward connections.
7 Ramping up and temperature 50° above local set point.	Possible relay failure in the closed position.	Turn Off and unplug. Check relay.
8 Controller in positive ramp, kiln temperature is ramping down. Negative rate must persist for 22.5 minutes to trigger error.	On Wall-Mount KM-1, The Kiln-Sitter may have tripped or timer depleted and turned Kiln-Sitter off.	Use hotter cone in Kiln-Sitter. Add more time to limit timer.
FAIL System cannot sense thermocouple.	Thermocouple broken or disconnected.	Secure or replace thermocouple.



Wiring Diagram
Automatic Kiln
Models:
KM-614
for kilns produced
after October 1997

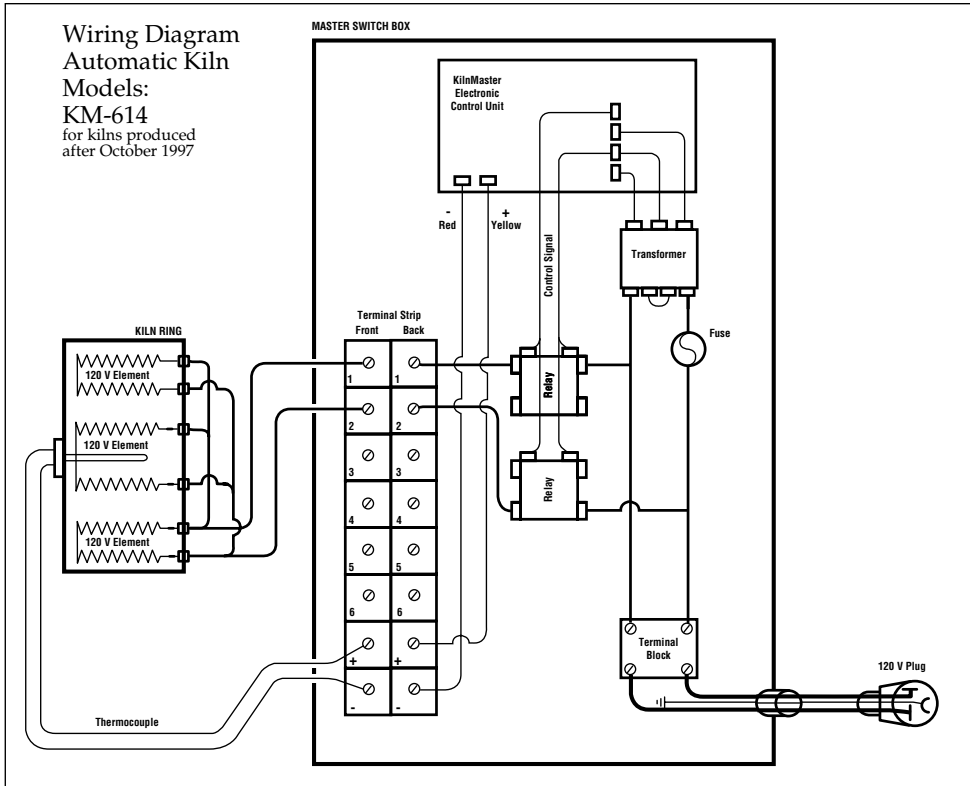

Wiring Diagram
Automatic Kiln
Models:
KM-714

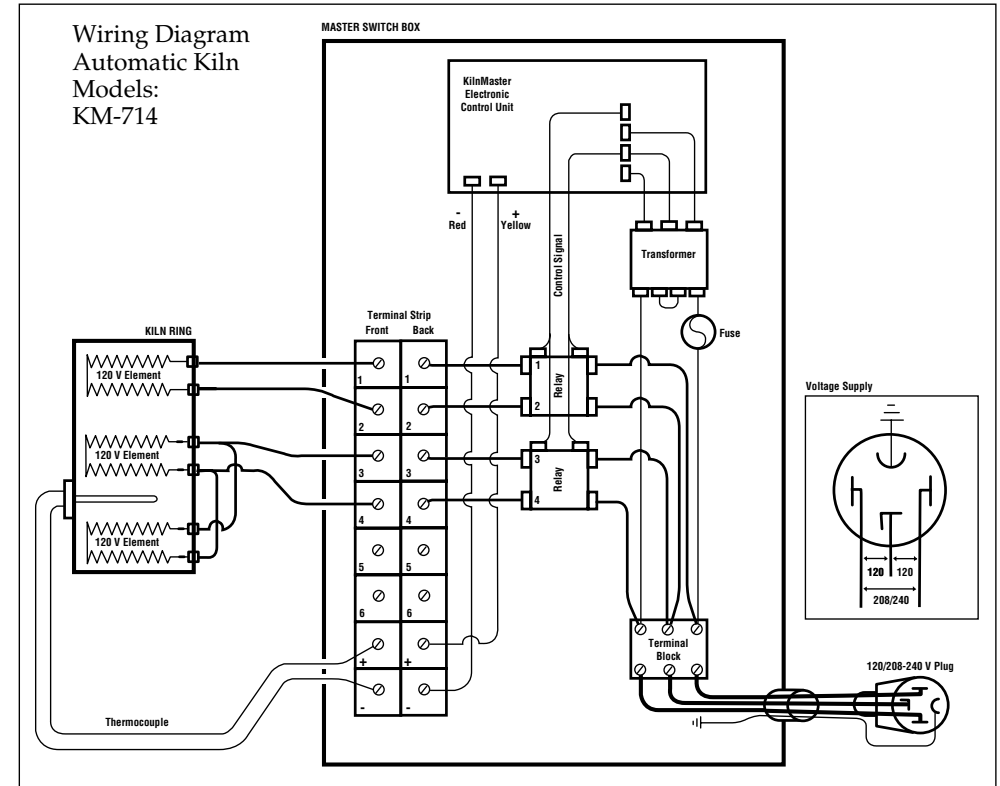

APPENDIX 5

Wiring Diagrams



Wiring Diagram
Automatic Kiln
Models:
KM-818
KM-818-30A

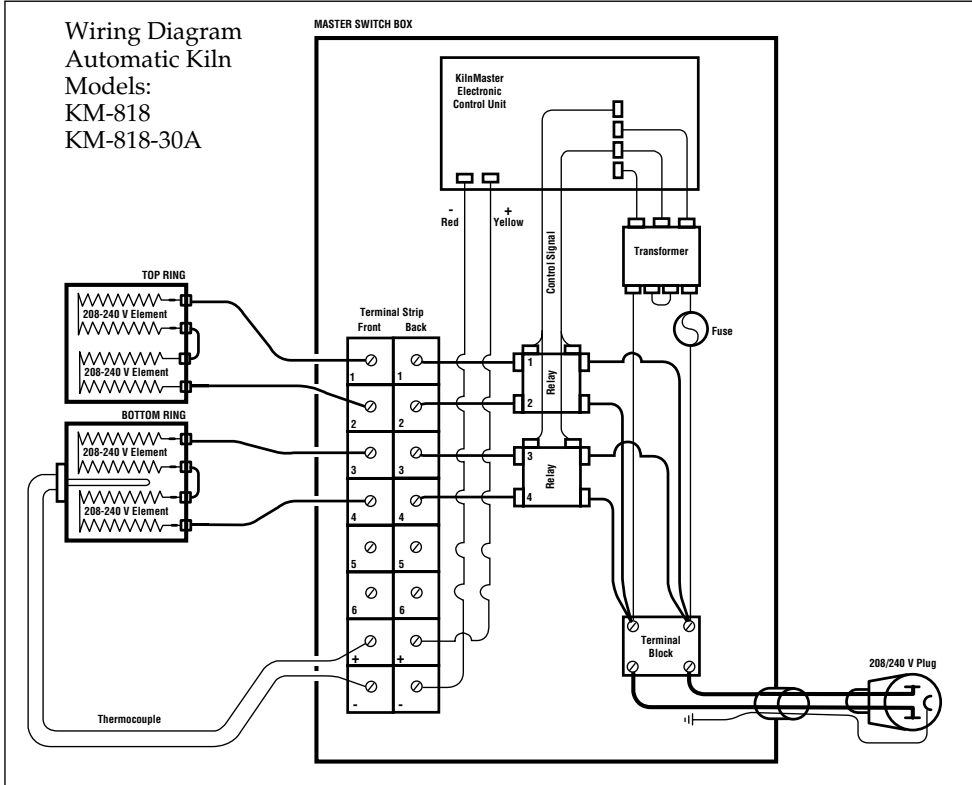

Wiring Diagram
Automatic Kiln
Models:
KM-1018

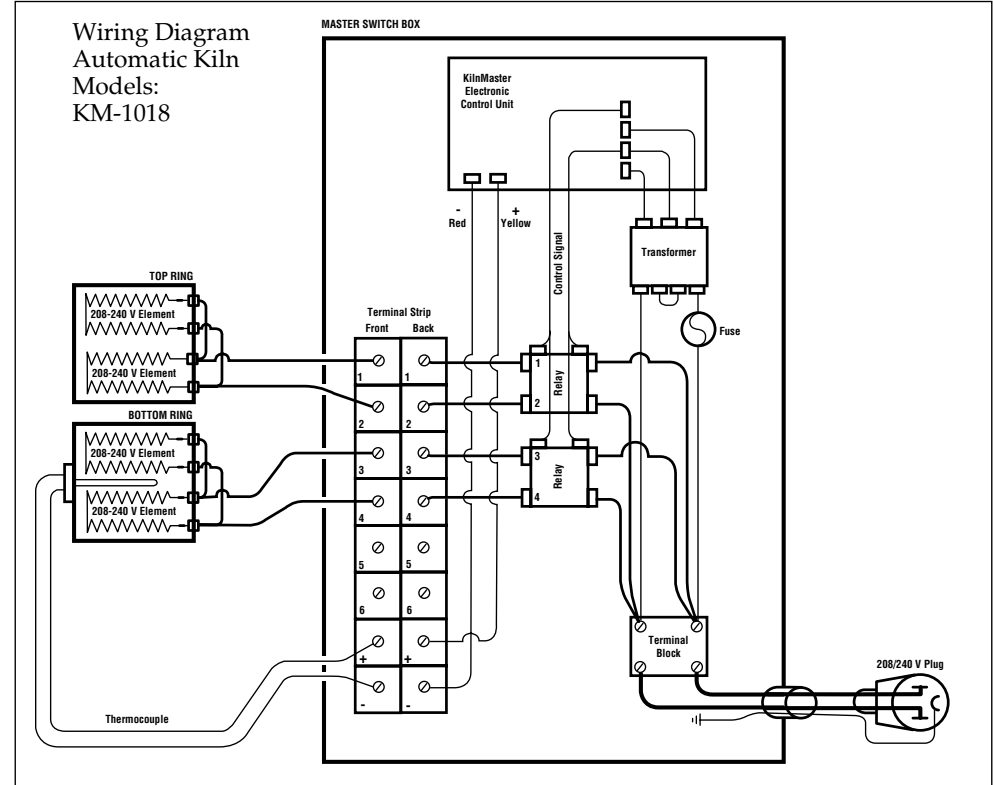



Wiring Diagram
Automatic Kiln
Models:
KM-1027
KM-1227

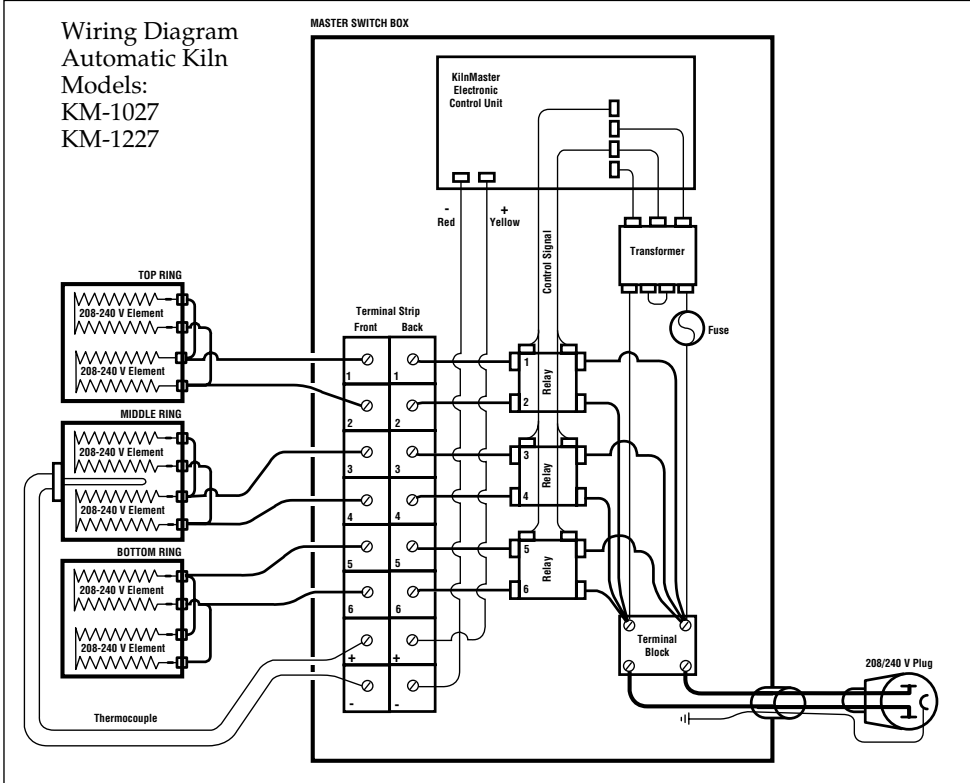

Wiring Diagram
Automatic Kiln
Models:
KM-1027, 3 Phase
KM-1227, 3 Phase

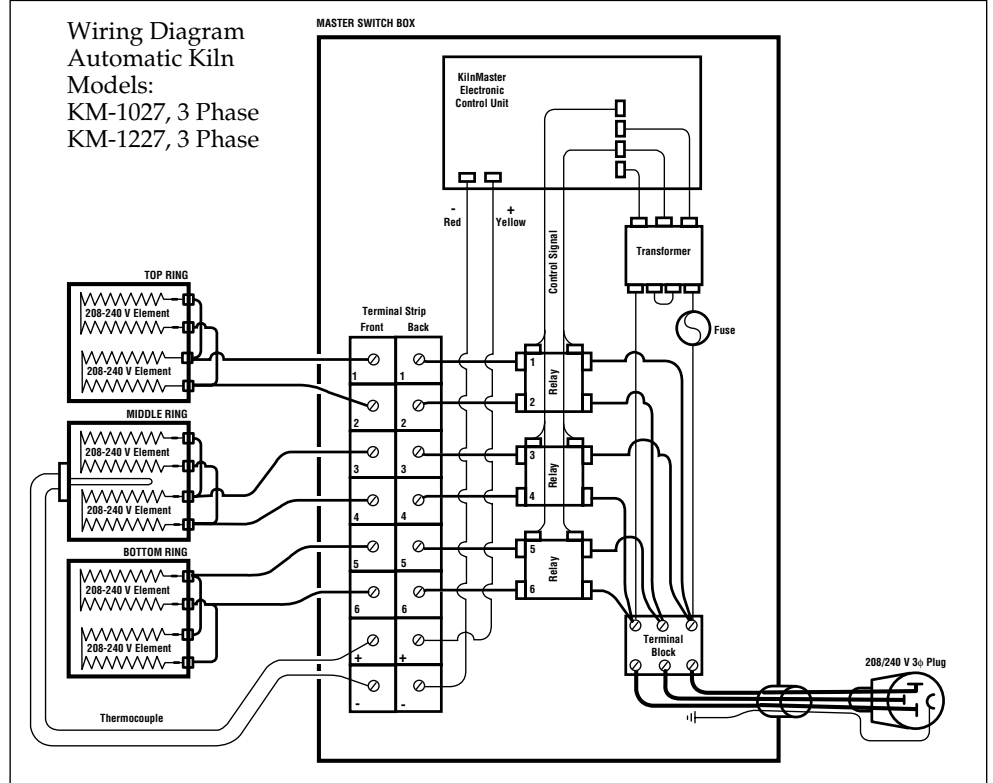



Wiring Diagram
KilnMaster
Controller
KM-1 Single Phase

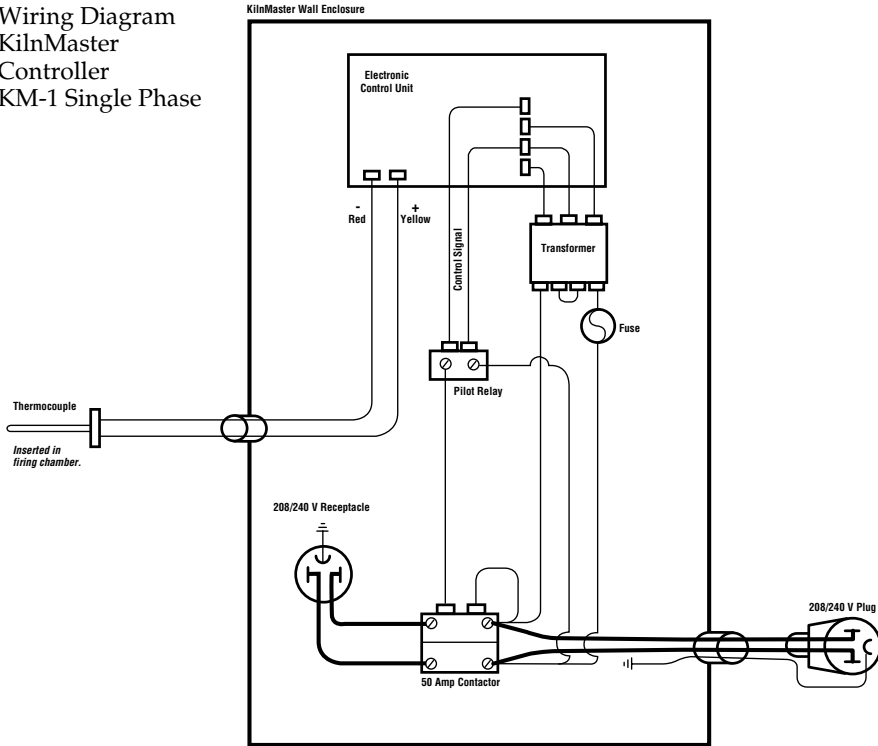

Wiring Diagram
KilnMaster
Controller
KM-1 Three Phase

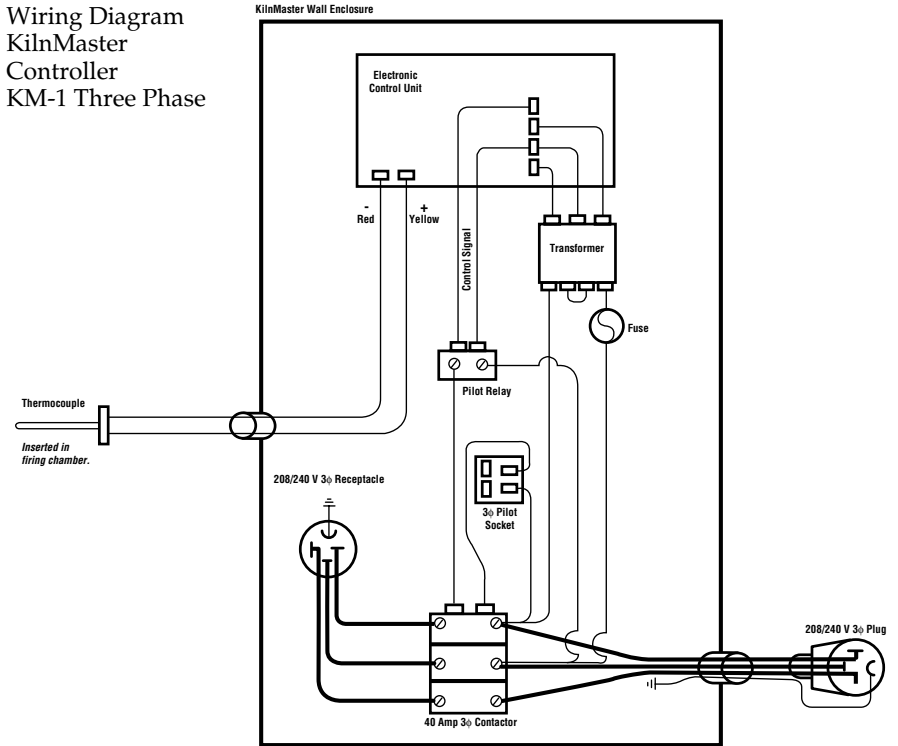



APPENDIX 6

Wall-Mounted KilnMaster UL Listing

The KM-1 wall-mounted KilnMaster controller is a UL-listed accessory when used with the following Skutt UL-listed kiln models.

1227-3, 280	240 or 208 volt
1227-3	240 or 208 volt 3 phase
1027-3	240 or 208 volt
1027-3	240 or 208 volt 3 phase
1027, 231, 235	240 or 208 volt
1027	240 or 208 volt 3 phase
1018-3	240 or 208 volt
1018, 231-18	240 or 208 volt
818-3	240 or 208 volt
818, 185	240 or 208 volt
818P-3	240 or 208 volt
818P, 181, 183	240 or 208 volt
714, 145	208-240 volt

APPENDIX 7

Set-up and specifications for Skutt PK production kilns

Skutt PK production kilns are heavy duty, high capacity units designed to meet the needs of the high fire production potter, tile maker and light industrial user. These kilns are equipped with upgraded components and wiring that will allow them to high fire extremely dense loads in a relatively short time.

The KM-1227PK is a twelve sided kiln similar in capacity to our KM-1227—27" deep and 9.92 cu. ft.

The KM-1231PK is 31" deep and offers 11.57 cu. ft. of capacity.

Both PK kilns are available in single and three phase, 240V or 208V.

FIRING

Skutt PK kilns feature our KilnMaster controller, so operation is identical to other KM kilns. Even though the earlier sections of this manual do not refer specifically to the PK kiln line, you may follow all the instructions on programming and firing routines.

KILN IMPROVEMENTS

If you are an intensive kiln user, you might find a PK kiln to be the appropriate choice for your next kiln purchase. Here are some the differences from our standard KM kiln line:

First, PK kilns are designed to fire full, Cone 10 loads without stalling on the high end. To do so, they are equipped with industrial gauge wiring and three types of elements for better firing balance. Because of their high rating, electrical codes require that they be direct wired by an electrician; therefore no plug is included.

Mercury displacement relays are used for longer life and quieter operation.

The hinged control box is larger, and compression connectors are used on the feeder wires for easier element replacement.

Finally, Model KM-1231PK comes with an additional stand for bottom slab support under heavy loads. This extra stand is not included when the kiln is ordered with a Skutt EnviroVent, which provides all the support needed.



UNPACKING AND MOVING PK KILNS

Follow the general instructions on kiln set-up found on pages 8 and 9 of this manual. You will probably want to separate the kiln into sections when you set it up or move it to a different location. These instructions are slightly different than for standard KM kilns.

Caution: Before disassembling any PK kiln, be sure to turn off power to the kiln by throwing the circuit breaker or removing the fuse on its circuit. Do not restore power to the kiln until it is fully reassembled.

Note: The mercury relays in the switch box must be operated only with the switch box in a normal, vertical orientation.

To disassemble the kiln

- 1 Remove the screws from the left side of the control box and swing the control box open.
- 2 Remove the screws holding the feeder wires to the two pole blocks on the heat baffle. There are three sets with two feeder wires going into each set.
- 3 Remove the thermocouple wires from the thermocouple terminal strip on the baffle. They are attached with slide on connectors and should be pulled straight off. Pulling at an angle can damage the connector.
- 4 Lift the box up and set it aside.
- 5 Unfasten draw pull catches and lift sections apart using the handles.

To reassemble PK kilns:

- 1 Stack the sections in original sequence and secure the draw pull catches..
- 2 Place the control box on its hinges.
- 3 Reattach the feeder wires to their corresponding block. **Make sure the connection is very tight** to avoid electrical problems.
- 4 Reattach the thermocouple wires making sure that the red wire (-) is secured to the red tab and the yellow wire is connected to the silver tab (+). On single zone kilns there will only be one set of thermocouples and they should be attached to the center group of tabs.
- 5 Reattach the screws which secure the control box to the kiln jacket.

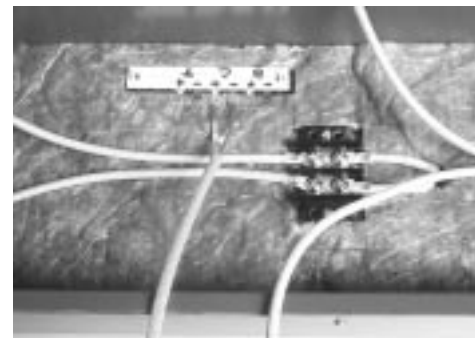
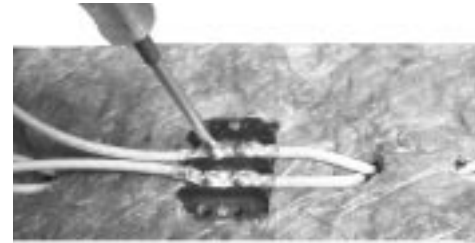
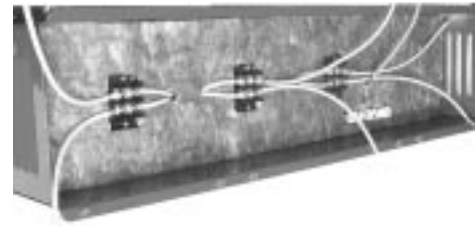



CONNECTING PK KILNS

As mentioned earlier, PK kilns must be direct wired or “hard wired” into your studio electric system by a qualified electrician. Flat and Phillips screwdrivers are the only tools required.

At the time of connection, your electrician should also check your electric wiring which supplies the kiln, to be sure that the copper wire size and breaker size are adequate for your PK kiln electrical requirements as shown in the table at right.

Electrical requirements for Skutt PK Production Kilns

Model	Volts	Amps	Watts	Max. Cone	Copper Wire Size*	Fuse or Breaker Size
KM-1231PK	240	72	17300	10	2	90
KM-1231PK	208	80	16640	10	2	100
KM-1231PK-3ph	240	44.5	17300	10	6	60
KM-1231PK-3ph	208	51.5	17300	10	6	60
KM-1227PK	240	60	14300	10	4	80
KM-1227PK	208	69	14300	10	2	90
KM-1227PK-3ph	240	40	14300	10	6	50
KM-1227PK-3ph	208	46.7	14300	10	6	60

**An electrician will need to make the electrical connection. The kilns are “hard wired” to allow for greater amperage. For each additional 50 feet use heavier wire, numerically two numbers lower—for example, instead of #6, use #4. If you anticipate installing any larger kiln in the future, use the heavier wire.*



PK KILN ELEMENTS

To achieve optimum heat distribution, there are three types of elements in the production kilns: Top/Bottom, Intermediate, and Center. The tables below show the proper placement and type when replacing elements.

KM-1227PK

Section	Element	Position
Upper	Top/Bottom	1
	Intermediate	2
Master	Center	3
	Center	4
Lower	Intermediate	5
	Top/Bottom	6

KM-1231PK

Section	Element	Position
Upper	Top/Bottom	1
	Intermediate	2
Master	Center	3
	Center	4
	Center	5
Lower	Intermediate	6
	Top/Bottom	7

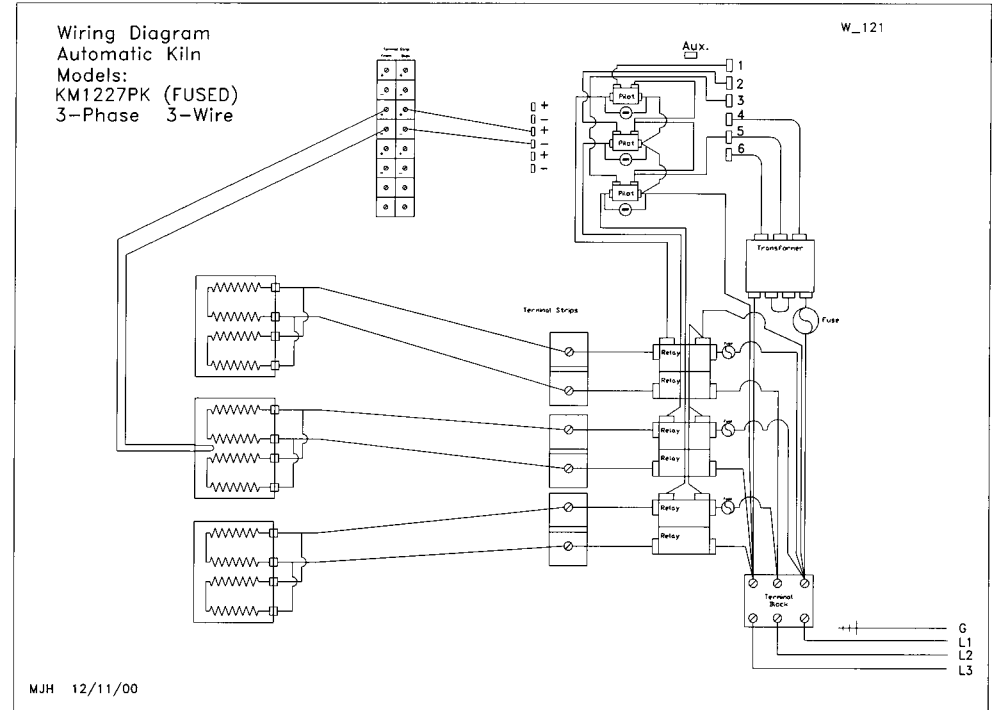
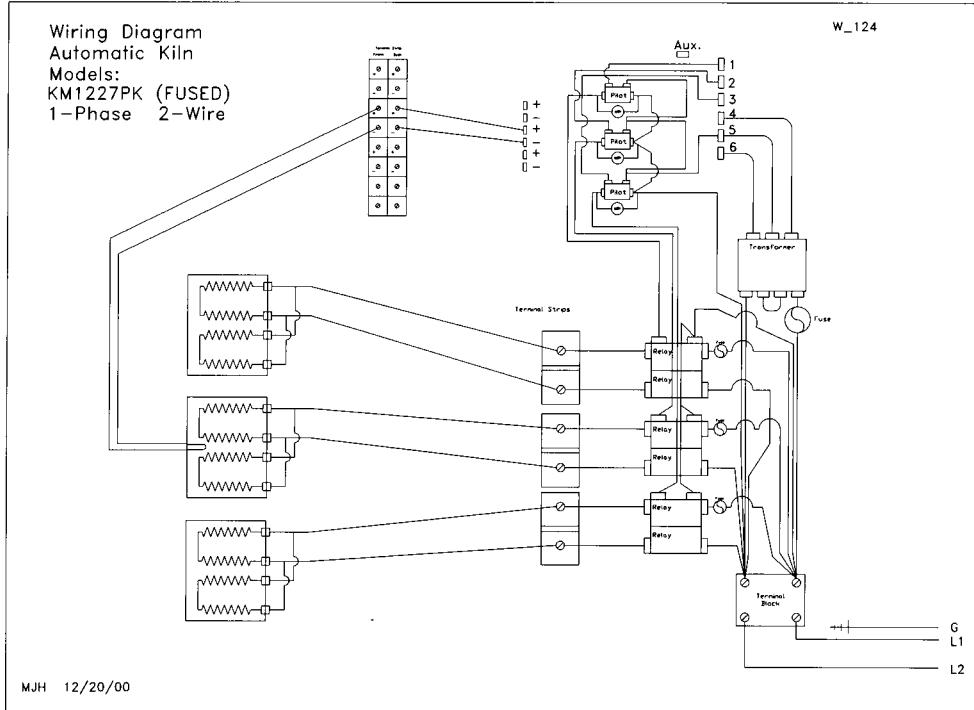



Wiring Diagram
Automatic Kiln
Models:
KM1231PK (FUSED)
1-Phase 2-Wire

W_125

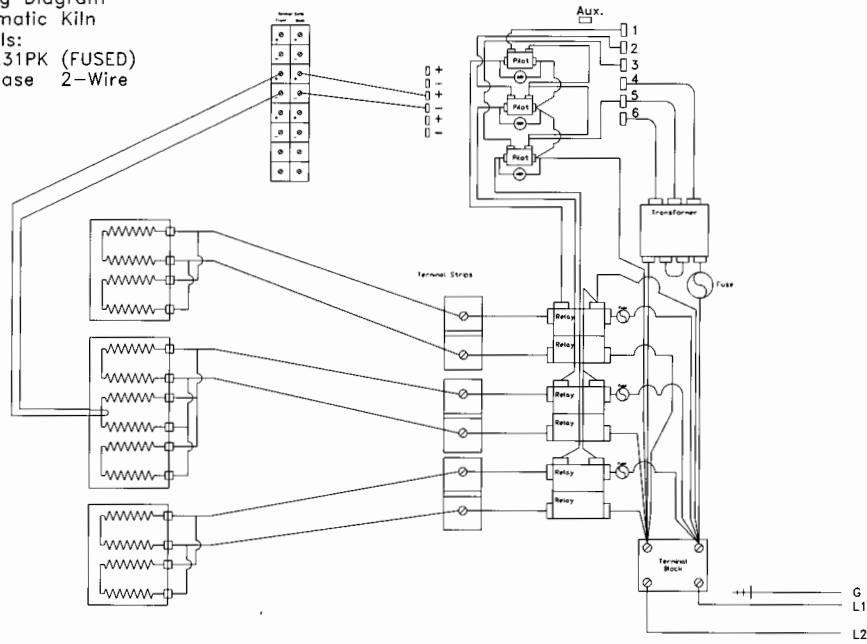

MJH 12/20/00

Wiring Diagram
Automatic Kiln
Models:
KM1231PK (FUSED)
3-Phase 3-Wire

W_122

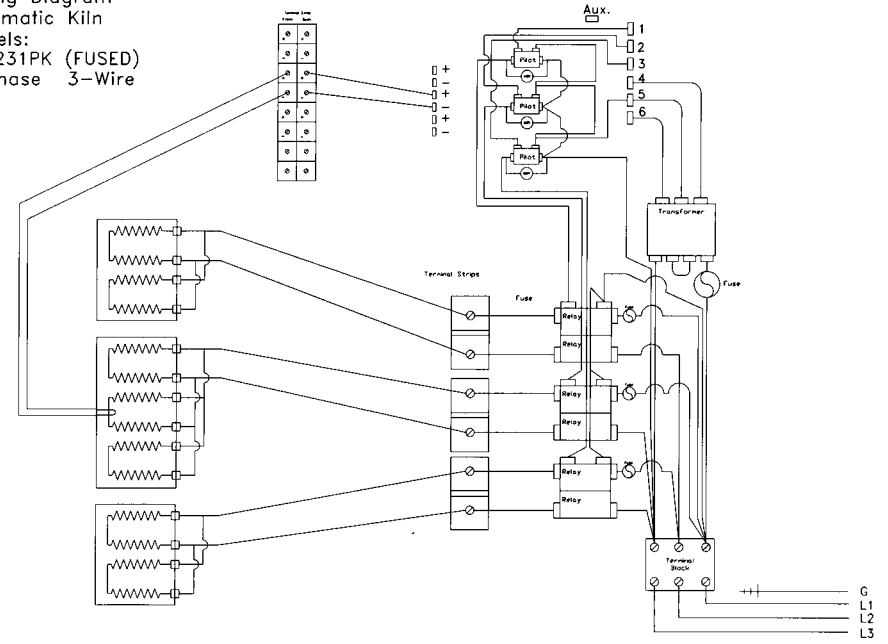

MJH 12/11/00



Index

- Aftercrazing 35
Alarm..... 2, 22, 24, 28
 ALAr..... 22, 24, 28, 39
Bisque35
Brick repairs..... 34
Candling 26, 35
Ceramic 35
Clean-up 35
Clear display 31
Clicking 11
Complete
 CPLt 22, 24, 39
Cone
 ConE 21, 38, 39
 deformation 37
 heat work 38
 value 29
Cone Fire 1, 19, 31
 description 1
 profiles 1, 19, 20, 21
 programming 21, 22
Cone plaque 35
Cone Table 4, 29, 38
Cones 12
 self-supporting 12
 senior 12
Controlled cooling 26
Controller 4
 connecting
 3 phase 6, 10
 single phase 6
 kiln settings 7
 Kiln-Sitter 7
 switches 7
 timer 7
 locating 6
 mounting..... 6
Crackle glaze 35
Cracks in the body 33
Crazing 33, 35
 delayed or aftercrazing 33
Crystalline glaze 27
Delay 22, 25, 28
 deLA 21, 22, 24, 39
Dipping 35
Display dim 32
Dry footing 14, 35
Electrical
 chart of specifications..... 10, 47
 3 phase..... 6, 10
 voltage 10
Element
 groove..... 35
 replacing 35
EnviroVent 16
Error
 Err 39
 messages 40
FAIL 39
Firebrick 35
Firing 16, 35
 after the firing..... 16
 china paint 16
 during the firing 18
 glass 14, 18, 27
 glaze 14, 16, 27
 greenglaze 16
 lusters 17
 metallics 16
 overglaze 14, 16
 oxidation 11
 porcelain 14, 17
 stoneware 14, 17
 underglaze 16
Floor repairs 34
Foot 35
Fuse, electrical 32, 37
Glass slumping 27
Glaze 14, 18, 35
 cloudy 33
 cratered or bubbled 32
 crawled 32
 excessive 33
 grainy 33
 red
 discolored 33
 grayed 33
 sagging 32
 textured 33
Greenware 13, 35
Heat work 37
Hold 24
 HLD 39
 HLD 1-8 25, 39
 HOLD 22, 39
Impurities 35
Incising 35
Kiln-Sitter 36
Kiln wash 11, 36
KilnMaster controller 4, 35
 features 1, 4, 19, 37
 wall mount
 repairs 7
Lid repairs..... 34
Limit timer 36
Loading 13, 15
 glass fusing 14
 glaze 14
 greenware 13
 overglaze 13
 porcelain 13
Locating kiln8
Lusters 17, 36
Mature 36
Multitester 36
Nesting 36

Ohm meter	36
One-fire	36
Overglaze	16, 36
discolored	33
PK Production Kilns.....	45
Peephole	15, 36
Peephole plug	15, 36
Pinholes	32, 36
Porcelain	17, 27, 36
Posts,	36
Pouring,	36
Power failure, PF	22, 25, 39
Pyrometer	36
Pyrometric Cone	12, 36, 38
Ramp/Hold	1, 26, 31, 37, 38
description	24
hold	24, 39
programming	25, 26
rate	24
temperature	24
Rate	
rA	39
rA 1-6	25
Refractory	36
Repairs	34
Wall repairs	34
Floor repairs	34
Lid repairs	34
KilnMaster repairs	7
Replacing elements	35
Replacing thermocouple	7, 8, 35
Review	29
Segment	24, 29
chart	24, 29
SEGS	23, 39
Sgraffito	36
Shelf	10, 36
Shiny matte surface	33
Shut off	
early	31
Slip	36
Soaking	36
Specifications	
fuse	37
Speed	
SPd	22, 39
Stilts	14, 36
Start firing	30
Stoneware	17, 36
Stop firing	30
Talc	36
Temperature	
flashing	1, 30, 39
scale selector	28
steady	39
Terminal brick	36
Terra cotta	36
Thermocouple	7, 36, 37
flaking	32
mounting	7
replacement	7, 35
Three-phase	
operation	6, 10
Time	
decreasing	39
Troubleshooting	31
fuses	32
Underglaze	16, 33, 36
Unpacking kiln	8, 46
User profile	2, 23
USER	2, 24, 39
Venting	15, 36
EnviroVent	15, 16
lid	15, 16
View	29
Vitreous	36
Volt meter	36
Ware	32, 36
Warpage	36
Wiring diagrams.....	41, 48



Segment	Rate	Temperature	Hold
1			
2			
3			
4			
5			
6			
7			
8			

Segment	Rate	Temperature	Hold
1			
2			
3			
4			
5			
6			
7			
8			

Segment	Rate	Temperature	Hold
1			
2			
3			
4			
5			
6			
7			
8			

Segment	Rate	Temperature	Hold
1			
2			
3			
4			
5			
6			
7			
8			



SKUTT

Skutt Ceramic Products
6441 S.E. Johnson Creek Blvd.
Portland, Oregon 97206-9594
Telephone (503) 774-6000 Fax (503) 774-7833

www.skutt.com
skutt@skutt.com